

Bally

MANUAL 4000
GAME 1017
FALL 75

MYSTIC GATE

SERVICE MANUAL & PARTS GUIDE

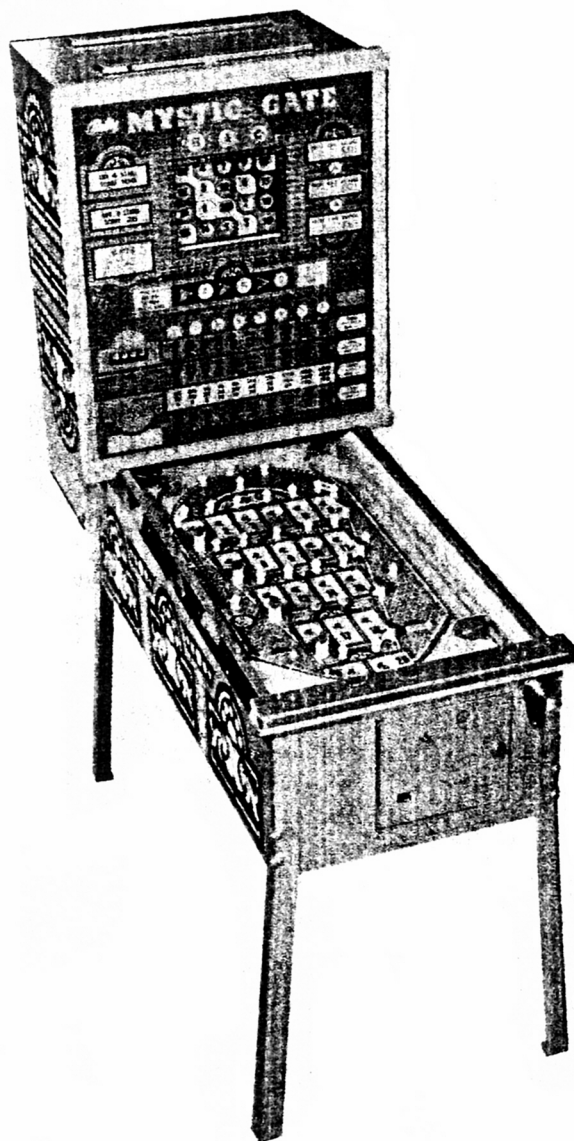

Bally

MANUFACTURING CORPORATION

2640 Belmont Avenue · Chicago, Illinois, 60618, U.S.A.

TELEPHONE (312) 267-6060/CABLE ADDRESS: BALFAN

MYSTIC GATE INTRODUCTION

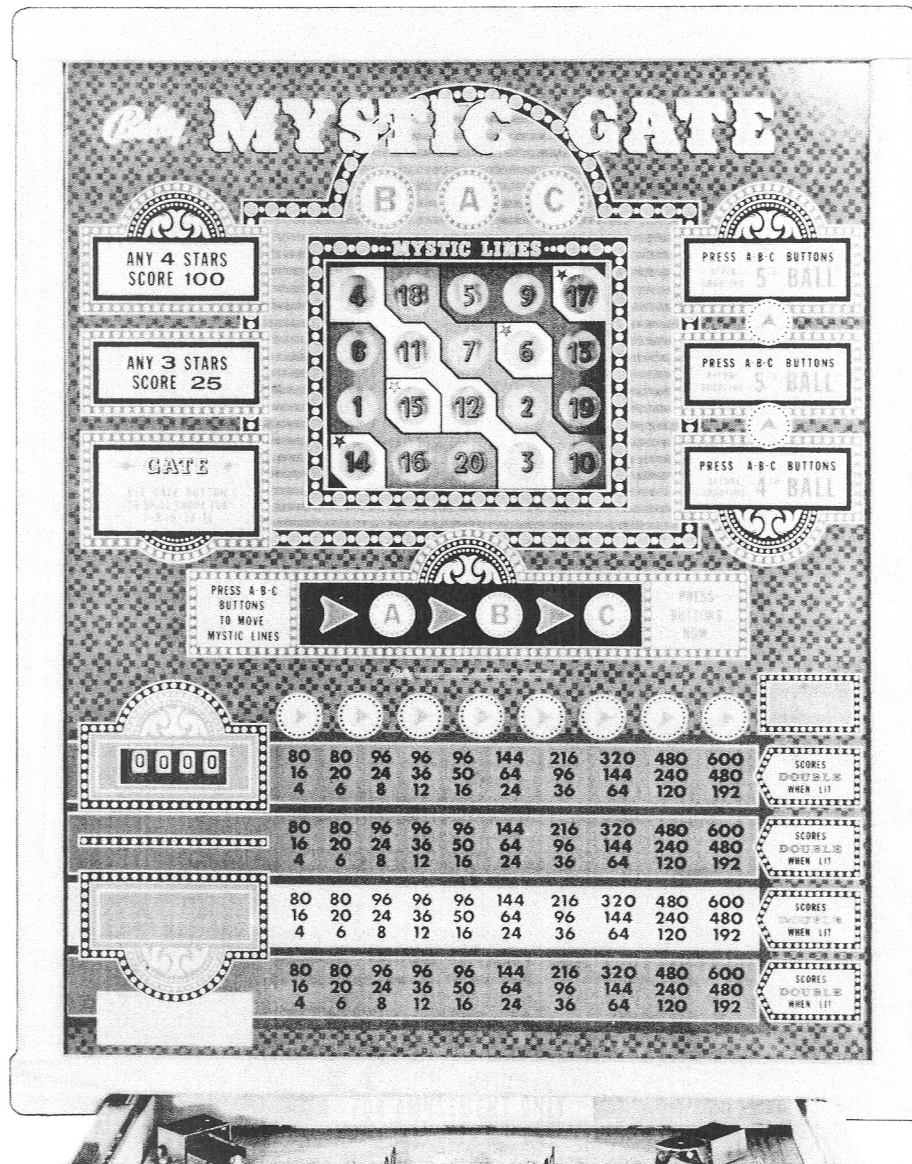

Mystic Gate is a newly developed feature which makes for an interesting attraction in game play. When Gate Feature is lit by coin or replay play, player may press Gate Button to open or close Gate at will. Open Gate allows ball to bypass top row of 6 holes, permitting player to combine skill-shot and

body-English to play for holes below top row, which may be needed to fill out a bingo win-line.

Double Score Feature is another new extra coin attraction. Double lights during coin or replay play, and doubles score in any of the 4-story score panels indicated by lit double light.

WIRE COLOR CODE	
1.... RED	A. FIRST NUMBER IS WIRE BODY COLOR
2.... BLUE	
3.... YELLOW	B. SECOND NUMBER IS TRACER COLOR STRIPE
4.... GREEN	
5.... WHITE	C. NUMBER AFTER DASH INDICATES RE-USE OF SAME COLOR WIRE IN A DIFFERENT CIRCUIT.
6.... BROWN	
7.... ORANGE	
8.... BLACK	
9.... GRAY	
0.... NO TRACER	

SWITCH CODE	
N.C.... NORMALLY CLOSED	
N.O.... NORMALLY OPEN	
N.B.B... MAKE BEFORE BREAK	
S.P.D.T. SINGLE POLE DOUBLE THROW OR TRANSFER SW. "T"	
NOTE: ALL SWITCHES ON BALLY DIAGRAMS WORK CLOCKWISE.	

MAINTENANCE & SERVICE SUGGESTIONS

To maintain a Game in good working order the game should be kept as clean as possible. Starting with the Coin Chute, for a great deal of Dirt, Metallic Coin Dust, and sticky beverages collect here. An aerosol type de-greaser or contact cleaner can be used, however all parts must be wiped off with a clean cloth to remove any residue & dissolved scum, especially on electrical contacts & printed Circuit Disc.

Keeping the Bottom Cabinet and Back Cabinet free and clear of extra loose parts, screws, nuts, and switch blades, eases trouble shooting; for broken or loose parts often turn up at the bottom of the cabinets making the troubled area easier to identify and correct.

Proper adjustments on Sw. Blades and Wipers should be maintained for proper electrical conduction and machine timing. Overly bent Sw. Blades will break off at the base. Wiper blades under too much pressure will cut through printed circuit discs. Wiper assemblies especially those assembled with multiple fibre discs are very susceptible electrical arcing when covered with even a thin coat of dirt & oil. Arcing will cause carbon traces to build up which will burn a hole through the fibre plates. Arcing shorts are hard to trace and play havoc with a circuit. Arcing can be checked for by giving discs and wipers a physical check.

Also check fibre cams for worn lobes or worn locking notches. In conclusion a clean machine is easier to maintain and keep in service.

CODE	
N.C.	NORMALLY CLOSED
N.O.	NORMALLY OPEN
M.B.B.	MAKE BEFORE BREAK
S.P.D.T.	SINGLE POLE DOUBLE THROW

BACK CABINET UNIT LAYOUT

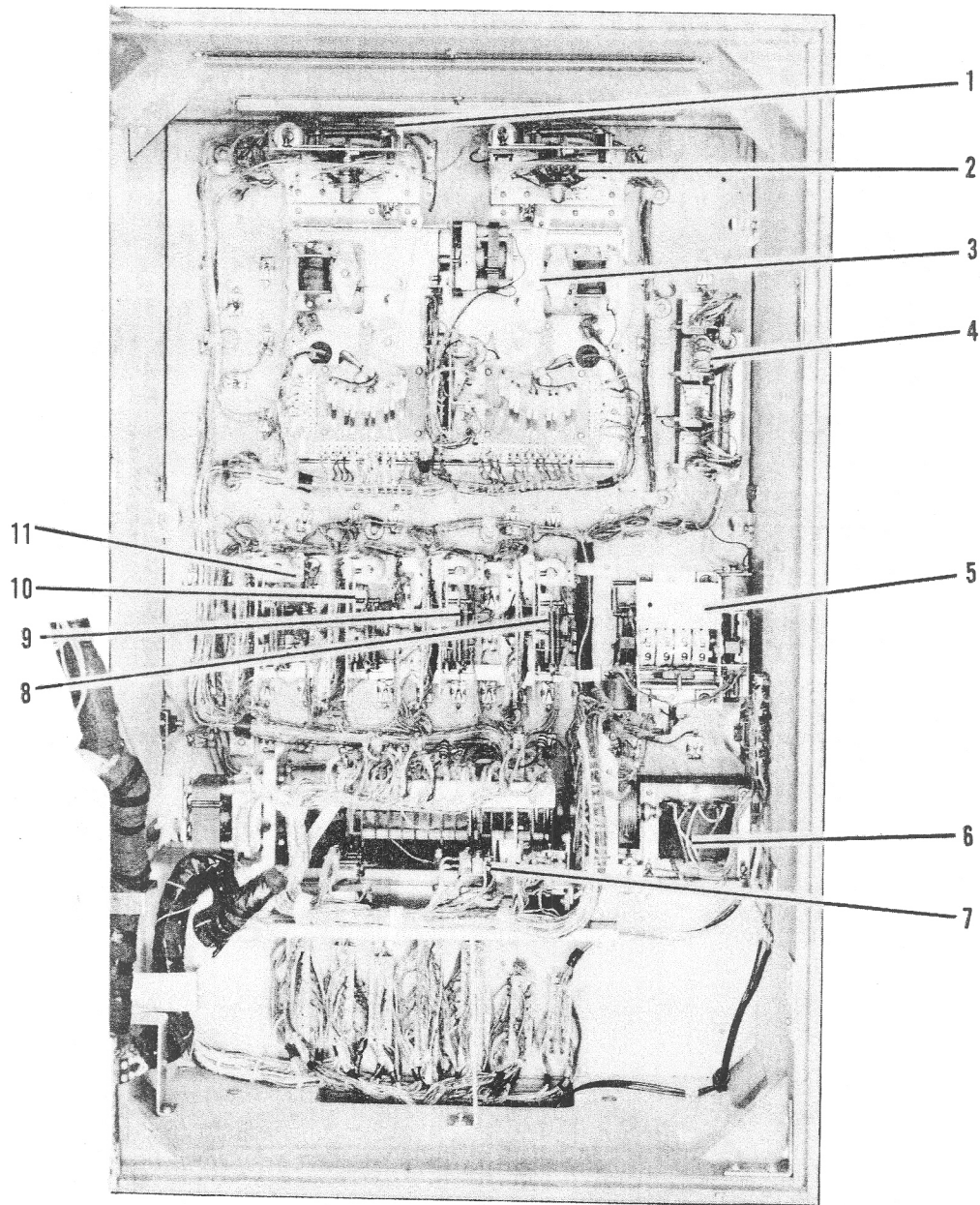

Index No.	Part No.	Description	Page No.
1	AS-827-576	SELECTION FEATURE UNIT	.32
2	AS-827-575	MYSTIC LINE FEA. UNIT	.31
3	AS-1809-10	MYSTIC LINES UNIT7-12
4	E-300-737	4 BANK RELAY.25
5	AS-473-54	REPLAY REGISTER27
6	E-122-103	TRANSFORMER	
7	AS-798-119	CONTROL UNIT12-17
8	AS-1148-35	BLUE SCORE COUNTER . .	.33
9	AS-1148-35	GREEN SCORE COUNTER . .	.33
10	AS-1148-35	YELLOW SCORE COUNTER .	.33
11	AS-1148-34	RED SCORE COUNTER33

ALWAYS GIVE MODEL AND PART NO. WHEN ORDERING SERVICE PARTS

BACK DOOR LAYOUT

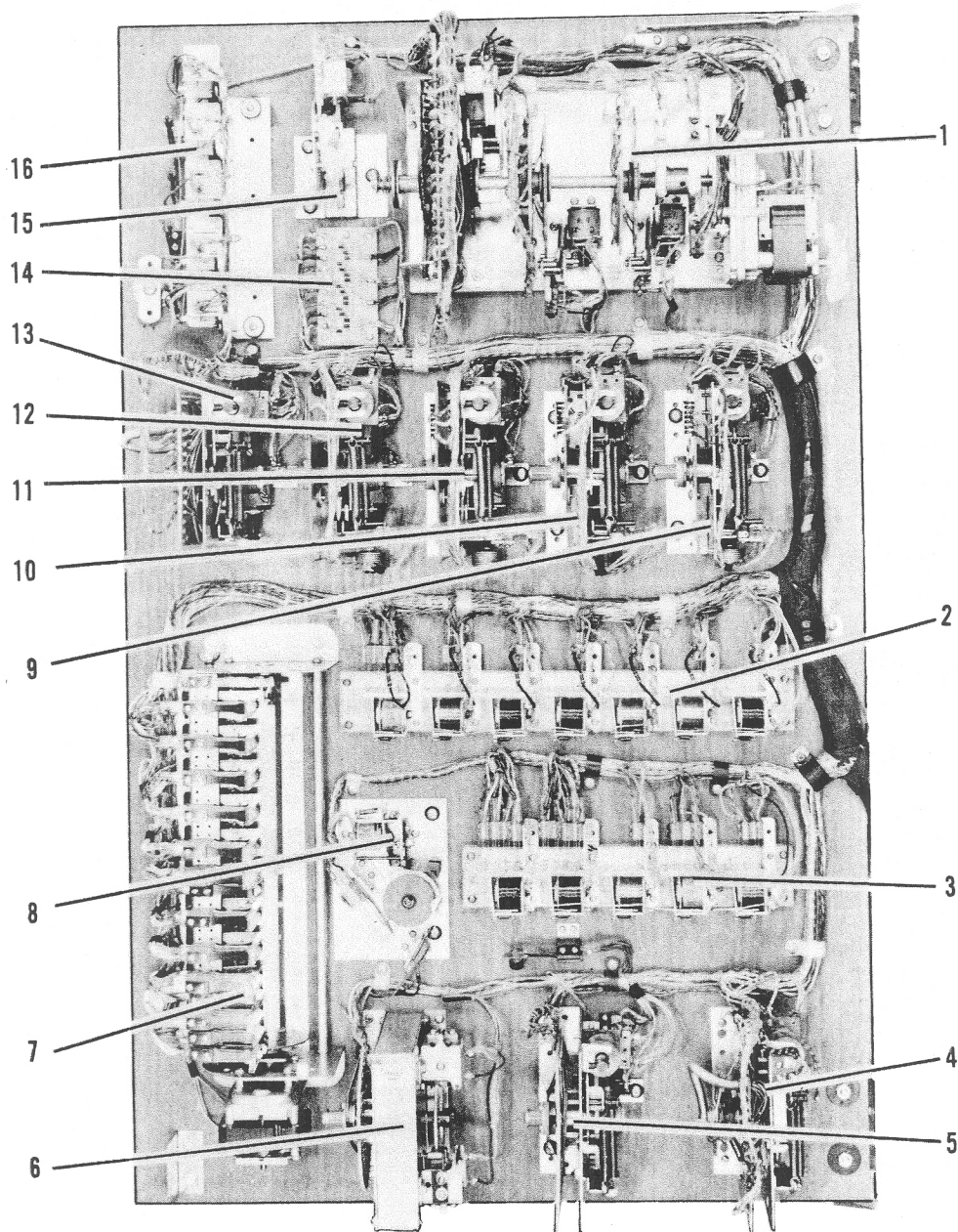

Index No.	Part No.	Description	Page No.
1	AS-1020-62	PROGRAM UNIT	18-19
2	E-300-739	7 RELAY BANK	23
3	E-300-738	5 RELAY BANK	24
4	AS-1022-147	SCRAMBLER UNIT	34
5	AS-1110-53	TIMER UNIT	29-30
6	AS-873-51	REFLEX UNIT	41
7	AS-2409-30	TRIP BANK ASSEMBLY	20-21
8	AS-1237-8	STAR REPLAY COUNTER	35-36
9	AS-797-302	BLUE COUNTER UNIT	26-27
10	AS-797-302	GREEN COUNTER UNIT	26
11	AS-797-302	YELLOW COUNTER UNIT	26
12	AS-797-302	RED COUNTER UNIT	26
13	AS-1358-26	COIN COUNTER	28
14	AS-2518-10	DIODE MTG. BOARD	
15	AS-1900-169	ALTERNATOR UNIT	37
16	E-300-632	SEARCH BANK 5 RELAY	22

ALWAYS GIVE MODEL AND PART NO. WHEN ORDERING SERVICE PARTS

LOWER FRONT CAB. UNITS

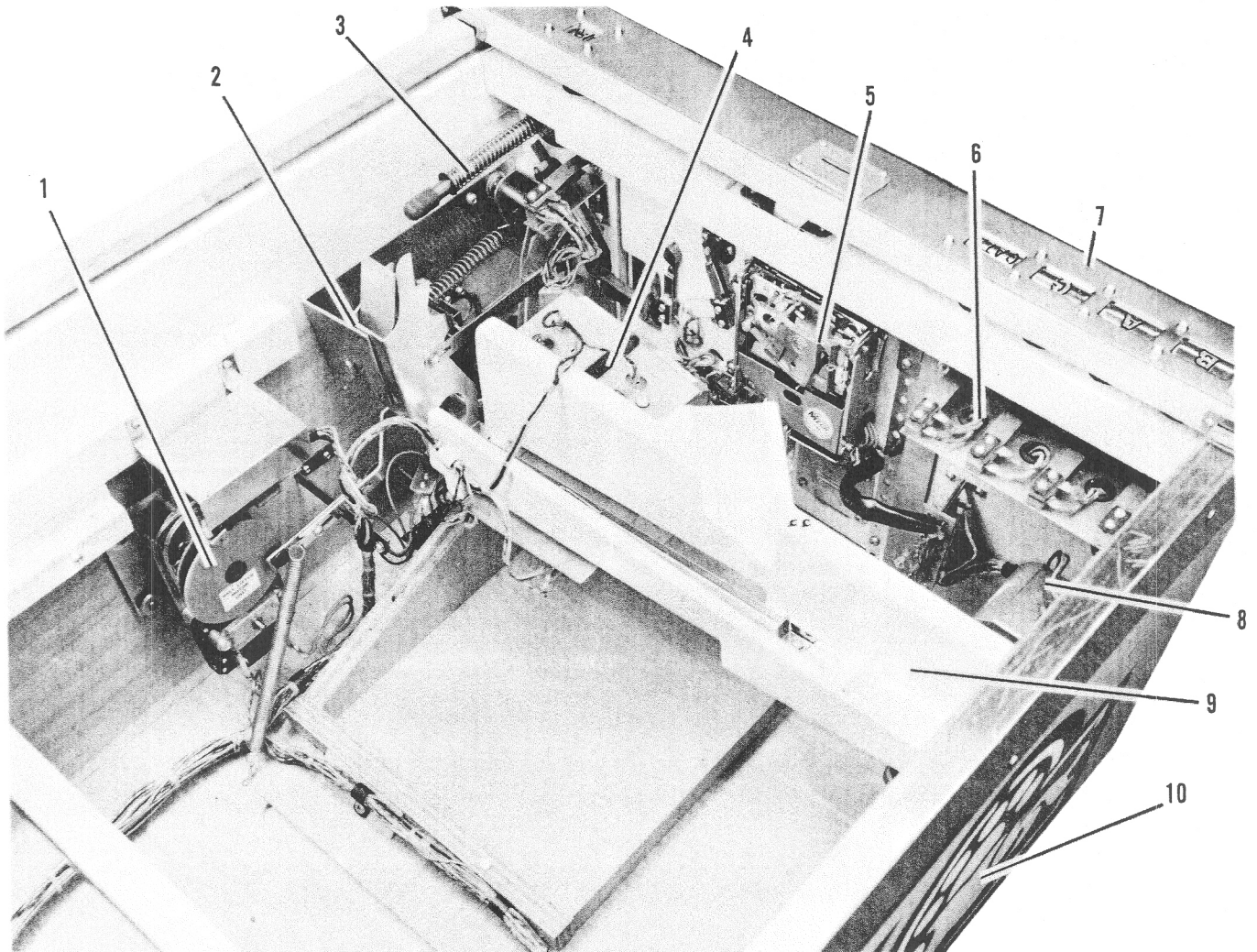

Index No.	Part No.	Description	Page No.
1	AS-1139-33	BALL LIFTER MOTOR ASSY.	38-39
2	AS-186-11	BALL LIFTER ASSY.	38-39
3	AS-187-17	BALL SHOOTER ASSY.	
4	E-130-10	COIN, KEY METER40
5	M-1400-COIN	SLUG REJECTOR	
6	AS-982-916	SW. & BRKT. ASSEM.40
7	AS-1305-60	FRONT MOLDING ASSEM.43
8	E-130-10	REPLAY METERS40
9	AS-1145-52	BALL TROUGH & SW. ASSM.	.40
10	M-281-54	LOCK	
	AS-982-1030	SW. & BRKT. ASSEMBLY.40
	AS-982-671	SW. & BRKT. ASSEMBLY (2 SW.)40-41

ALWAYS GIVE MODEL AND PART NO. WHEN ORDERING SERVICE PARTS

PLAYFIELD PANEL

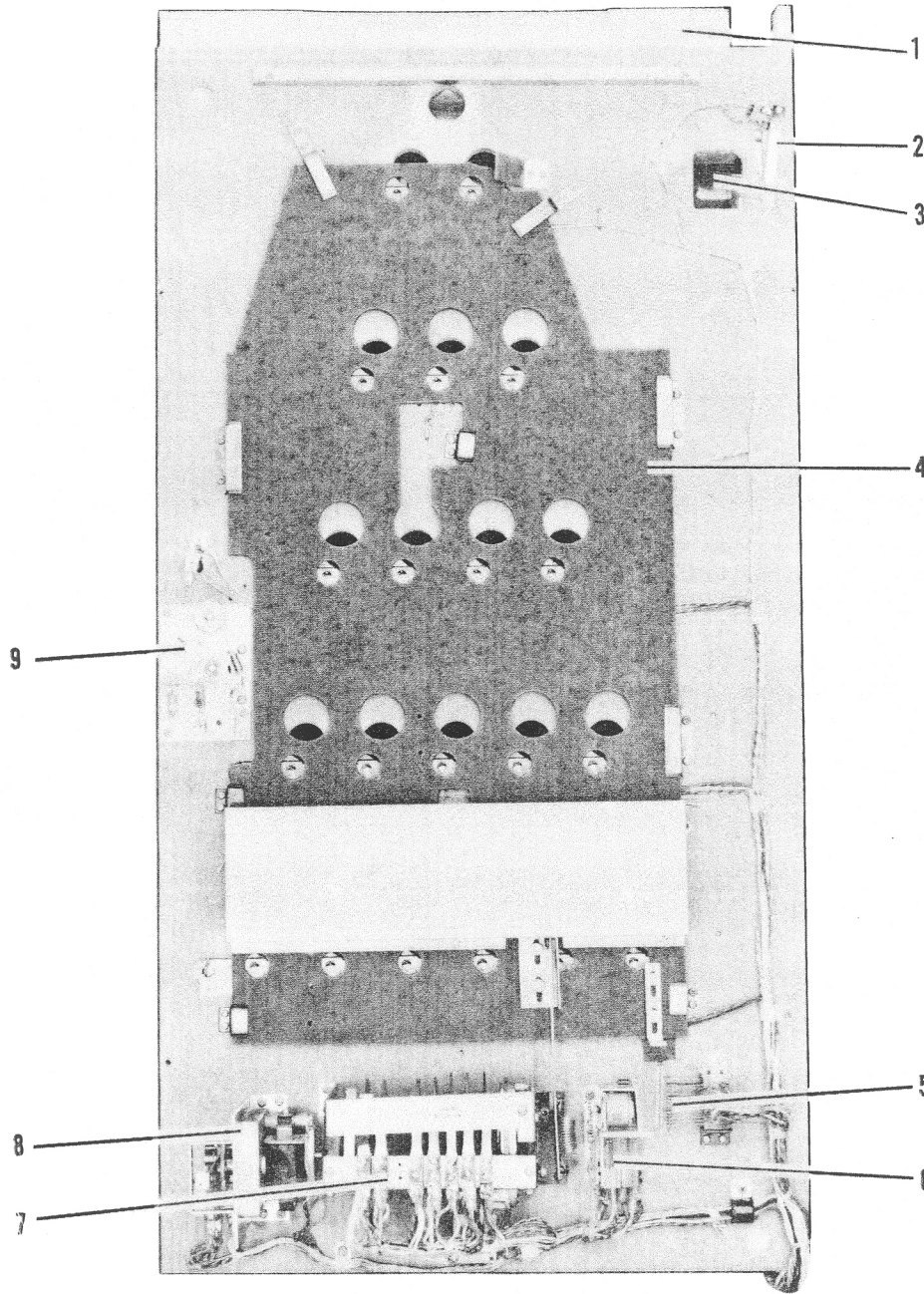

Index No.	Part No.	Description	Page No.
1	CA-1100-9	ARCH BOTTOM43
2	ASW-A1-30	BALL RUNWAY SW.39
3	C-153	RED PLASTIC COVER	
4	AS-1433-15	SHUTTER ASSEMBLY.43-44
5	AS-982-1025	PANEL SWITCHES.39
6	AS-2659-266	"G" RELAY ASSEMBLY.38
7	AS-232-90	SHUTTER MOTOR ASSEM.38
8	AS-2805	BALL GATE MOTOR ASSEM.	
9	A-2747-9	REBOUND ARM ASSEM.	

ALWAYS GIVE MODEL AND PART NO. WHEN ORDERING SERVICE PARTS

MYSTIC LINES UNIT-FRONT VIEW

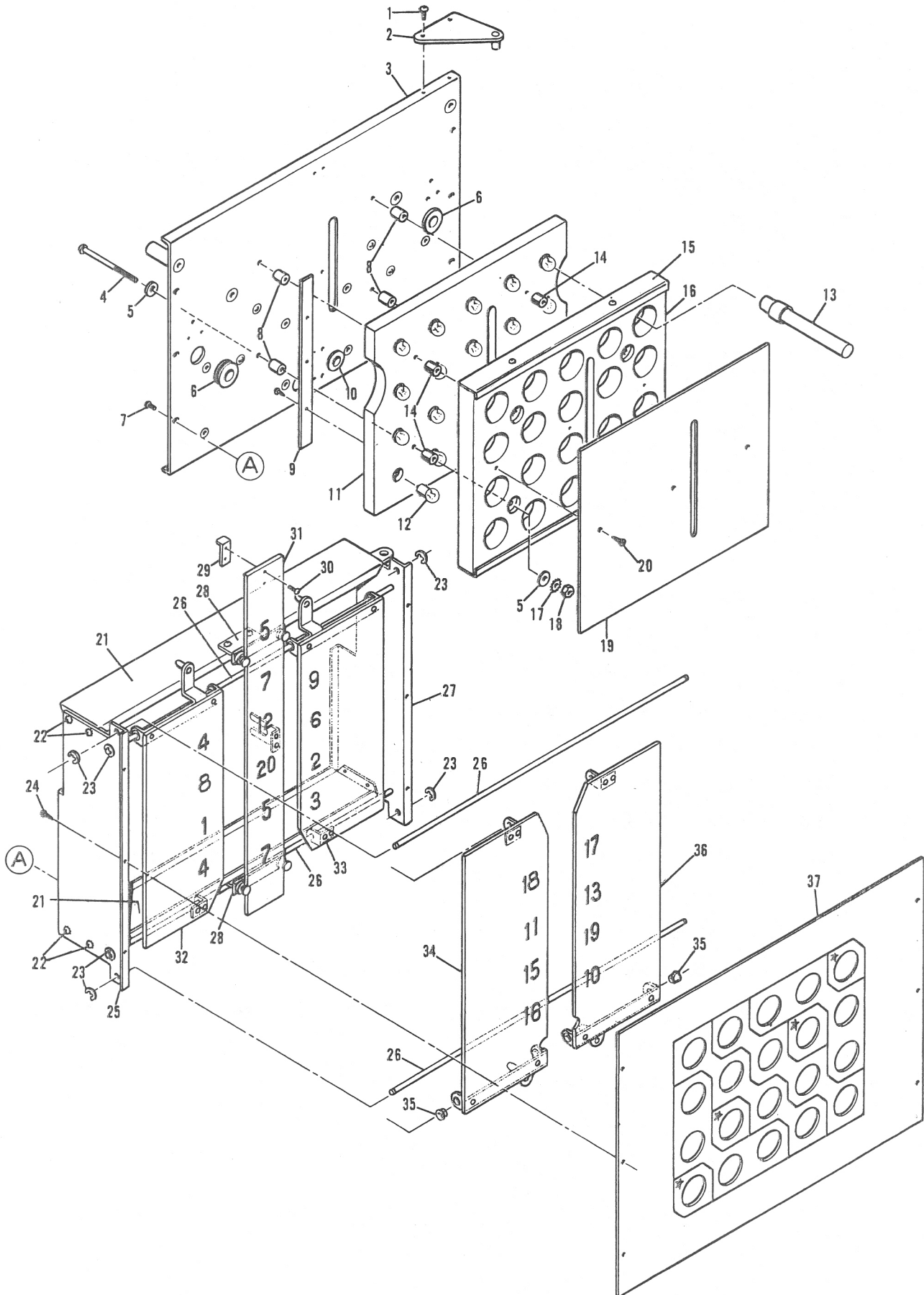

ALWAYS GIVE MODEL AND PART NO. WHEN ORDERING SERVICE PARTS

MYSTIC LINES UNIT-FRONT VIEW

Index No.	Part No.	Description	No. Req.	Index No.	Part No.	Description	No. Req.
<p>Note: This Illustration & Parts List shows the front illuminated "Score Card Portion" of the "Safari Mystic Lines Unit", AS-1809-10 ND.</p>				<p>Note: Index No.'s 21 - 37 comprise the Hinged Portion (Giving Access to Light Bulbs) of the Mystic Lines Unit. The Unit is shown in a semi-assembled state to aid in assembly clarity.</p>			
1	LS 632-3-511	Screw	4	21	P-6598A	Side Support Bracket (Top & Bottom)	2
2	A-2997A	Hinge Plate Assembly - Top	1	22	LS 632-3-511	Screw	8
	A-2997-1A	Hinge Plate Assembly - Bottom	1	23	P-6316-4A	Retaining Ring	8
3	A-3000B	Base Plate Assembly	1	24	WS 8-8-510	Wood Screw (Holds Mystic Lines Unit to the Back Cabinet Insert Panel	6
4	LS 1032-38-511	Screw	4			#8 Lockwasher - External Tooth	6
5	PW 10-11	Washer	8	25	P-6587B	End Plate (Left)	1
6	R-111-37A	Grommet (Wire Tunnel)	2	26	S-739-166A	Guide Rod	4
7	LS 832-3-511	Screw (Secures the Hinged Portion)	2	27	P-6587-1B	End Plate (Right)	1
8	S-231-688B	Spacer Bushing	4	28	A-2995A	"A" Strip Guide Bracket Assembly	2
9	P-5447-2A	Insulator Strip (Bakelite)	5		LS 832-3-511	Screw	4
10	R-111-8A	Grommet (Wire Tunnel)	1	29	P-6606A	Stop Bracket	1
11	CA-967-4B	Auxiliary Wood Insert	1	30	MS 440-4-511	Screw	2
	A-1653-1B	Lamp Socket Assembly	20	31	A-2990A	3rd Row Assembly	
12	E-125-47A	Lamp (1464)	20	32	A-2989A	2nd Row Assembly	1
13	AS-1115A	Light Bulb Removing Tool	1		C-537-3A	Nyliner (Top Slide Bar)	2
14	S-231-687B	Spacer Bushing	4	33	A-2991A	4th Row Assembly	1
15	P-6601A	Guide Rail (For Plastic Overlay)	2		C-537-3A	Nyliner (Top Slide Bar)	2
16	CA-9670 - 5B	Auxiliary Wood Insert - Overlay	1	34	A-2988A	1st Row Assembly	1
17		#10 Lockwasher	4	35	C-537-3A	Nyliner (Bottom Slide Bar)	4
18	N 1032-1111	Nut	4	36	A-2992A	5th Row Assembly	1
19	M-1423A	Plastic Overlay	1	37	P-6588A	Front Plate	1
20	WS 6-8-911	Flat Hd. Wood Screw	3				

ALWAYS GIVE MODEL AND PART NO. WHEN ORDERING SERVICE PARTS

MYSTIC LINES UNIT-REAR VIEW

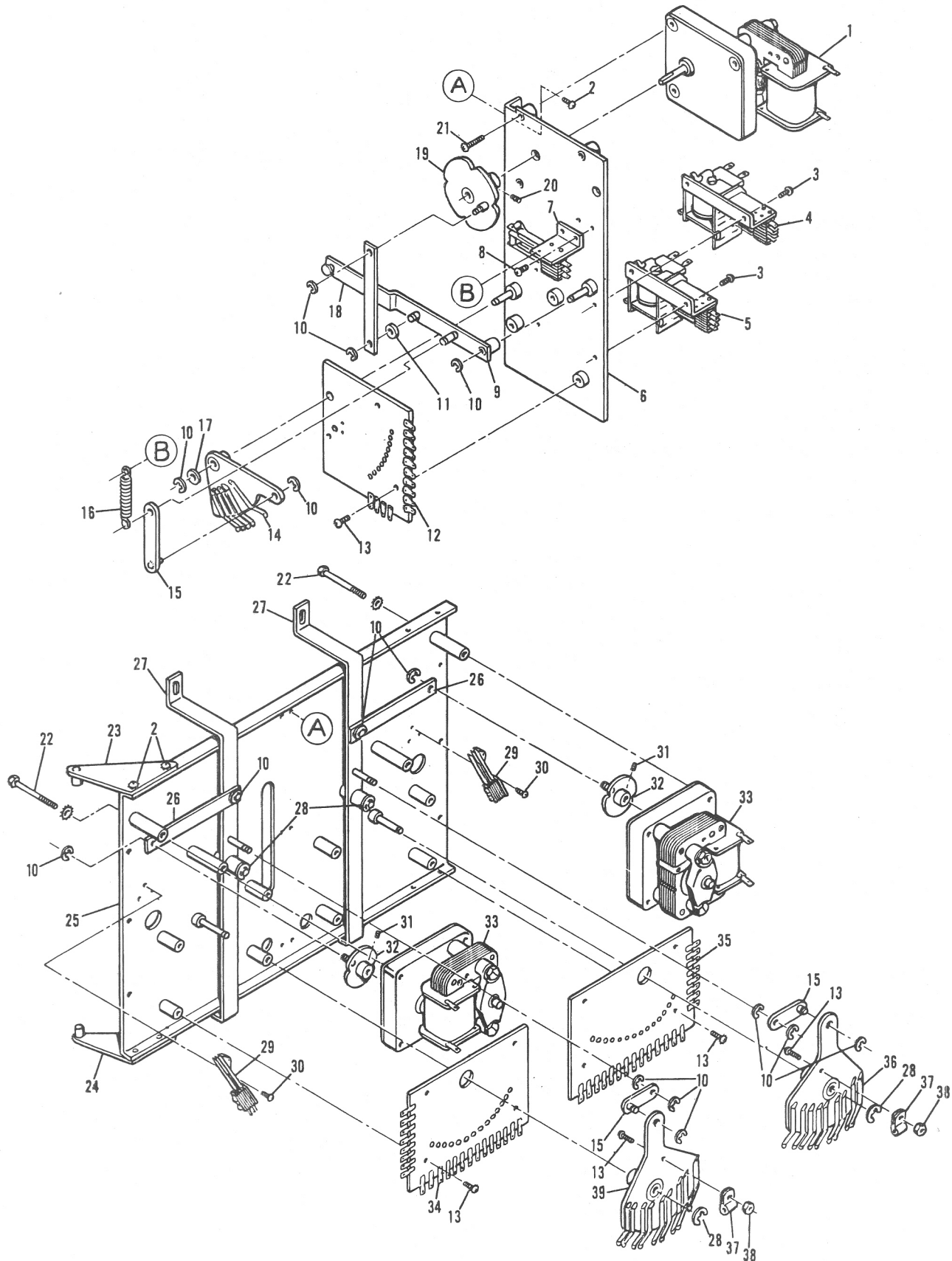

ALWAYS GIVE MODEL AND PART NO. WHEN ORDERING SERVICE PARTS

MYSTIC LINES UNIT-REAR VIEW

Index No.	Part No.	Description	No. Req.	Index No.	Part No.	Description	No. Req.
1.	E-119-457	Motor (25 R.P.M.) Line Row #3	1	22	LS 1032-24-811	Hex. Hd. Screw	4
2	LS 832-3-511	Screw (Mounts Unit)	3	23	A-2997A	Hinge Plate Assembly - Top	1
3	LS 632-3-511	Screw (Relays)	4		LS 632-3-511	Screw	2
4	E-146-618A	"KK" Relay ("B" Cam Relay)	1	24	A-2997-1A	Hinge Plate Assembly - Bottom	1
5	E-146-618A	"KK" Relay ("C" Cam Relay)	1		LS 632-3-511	Screw	2
6	A-3001-1B	Drive Link Plate Assembly	1	25	A-3000B	Base Plate Assembly	1
7	AS-982-535A	Switch & Bracket Assembly	1	26	P-1973-125A	Link (Shown Assembled)	2
	SW-110-130A	Switch	1	27	A-2998-1A	Drive Bracket Assembly (Moves Mystic Lines Slats-Shown in Operating Position)	2
8	LS 632-3-511	Screw	2	28	P-6316-6A	Retaining Ring (1/4" Dia. Shaft)	4
9	A-2996-1A	"A" Cam Pivot Arm Assembly (Row #3)	1	29	AS-982-579A	Switch & Bracket Assembly	2
10	P-6316-4A	Retaining Ring	15		SW-100-471A	Switch	2
11	P-801-393B	Washer	1	30	LS 632-3-511	Screw	4
12	A-101-356A	Contact Plate Assembly ("A")	1	31	SS 832-3-1101	Set Screw	2
	W-1063-3A	Contact Plate Wiring	1	32	A-800-131A	Cam & Hub Assembly ("B" & "C")	2
13	MS 832-6-511	Screw (Contact Plates - Clips)	13	33	E-119-353A	Motor (45 R.P.M.)	2
14	A-1371-114A	Wiper Arm Assembly ("A")	1	34	A-101-275A	Contact Plate Assembly ("C")	1
15	A-2999-1A	Wiper Drive Link Assembly	3		W-1063-2A	Contact Plate Wiring	1
16	SP-100-245B	Extension Spring	1	35	A-101-276A	Contact Plate Assembly ("B")	1
17	PW 10-11	Washer	1		W-1063-1A	Contact Plate Wiring	1
18	P-1973-124A	Link	1	36	A-1371-95A	Wiper Plate Assembly ("B")	1
19	A-800-130A	Cam & Hub Assembly ("A")	1	37	C-271-2A	Clip	2
20	SS 832-3-1101	Set Screw	1	38	N 832-1111	Nut	2
21	LS 1032-12-511	Screw	3	39	A-1371-96A	Wiper Plate Assembly ("C")	1

ALWAYS GIVE MODEL AND PART NO. WHEN ORDERING SERVICE PARTS

MYSTIC LINES MOTORS

Switch/Coil	Part No.	Location on Diagram	Wire No.	Wire Color	Function
"A" Cam Motor	E-119-353	G-4	70 13-5	Orange Red-Yellow	Energizes "A" Motor
A. N. O.	ASW-C1-12	H-4	13-5 21-3	Red-Yellow Blue-Red	Complete Circuit to "A" Motor
B. N. C.	ASW-C2-2	G-23	10-1 18-4	Red Red-Black	Opens Circuit to "B" and "C" Relay Sws.
"B" Cam Motor	E-119-457	G-4	70 80-20	Orange Black	Energizes "B" Motor
A. N. O.	ASW-C1-11	H-4	80-20 21-3	Black Blue-Red	Completes Circuit "B" Motor
"C" Cam Motor	E-119-353	G-5	70 31-19	Orange Yellow-Red	Energizer "B" Motor
A. N. O.	ASW-C1-11	H-5	21-3 31-19	Blue-Red Yellow-Red	Completes Circuit to "B" Motor
"B" Cam Relay	G-33-2800	B-4	70 80-20	Orange Black	Energizes "B" Cam Relay
A. N. C.	ASW-R2-5	H-6	25-6 31-19	Blue-White Yellow-Red	Opens "C" Cam Relay Circuit
B. N. C.	ASW-R2-5	H-5	40-13 45-5	Green Green-White	Opens "A" Cam Relay Circuit making "A" Button inoperable
C. N. C.	ASW-R2-5	G-23	18-4 54-7	Red-Black White-Green	Opens Circuit to "A" Cam Relay Sw.
"C" Cam Relay	G-33-2800	G-5	70 31-19	Orange Yellow-Red	Energizes "C" Cam Relay
A. N. C.	ASW-R2-5	H-4	13-5 40-13	Red-Yellow Green	Opens "A" Button Circuit and "B" Cam Relay Sw.
B. N. C.	ASW-R2-5	G-23	54-7 50-9	White-Green White	Opens Circuit to "A" and "B" Relay Sws.
C. N. C.	ASW-R2-5	H-5	80-20 48-5	Black Green-Black	Open "B" Button Circuit

ALWAYS GIVE MODEL AND PART NO. WHEN ORDERING SERVICE PARTS

CONTROL UNIT WINNER SEARCH POSITION CHART

MYSTIC LINES MOTOR UNIT DISCS

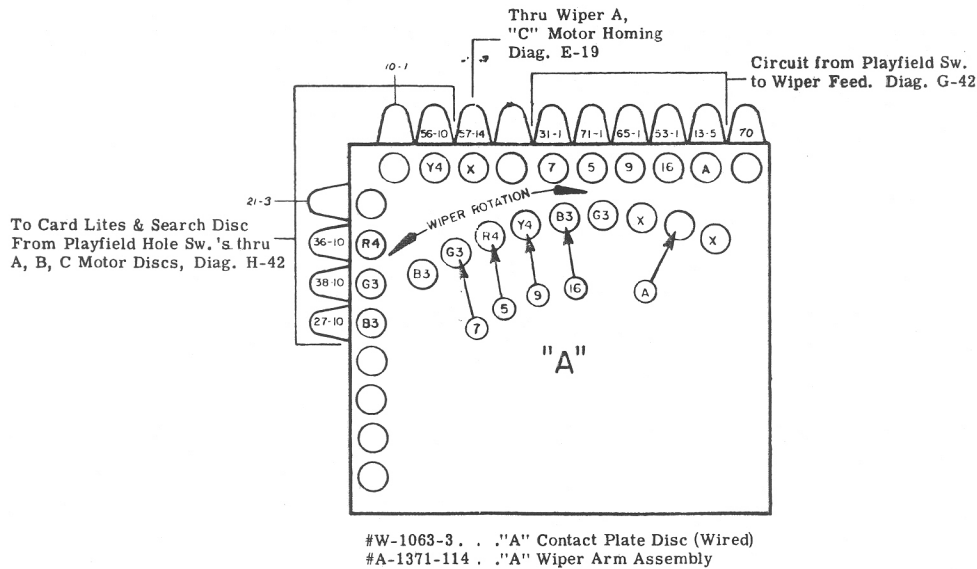
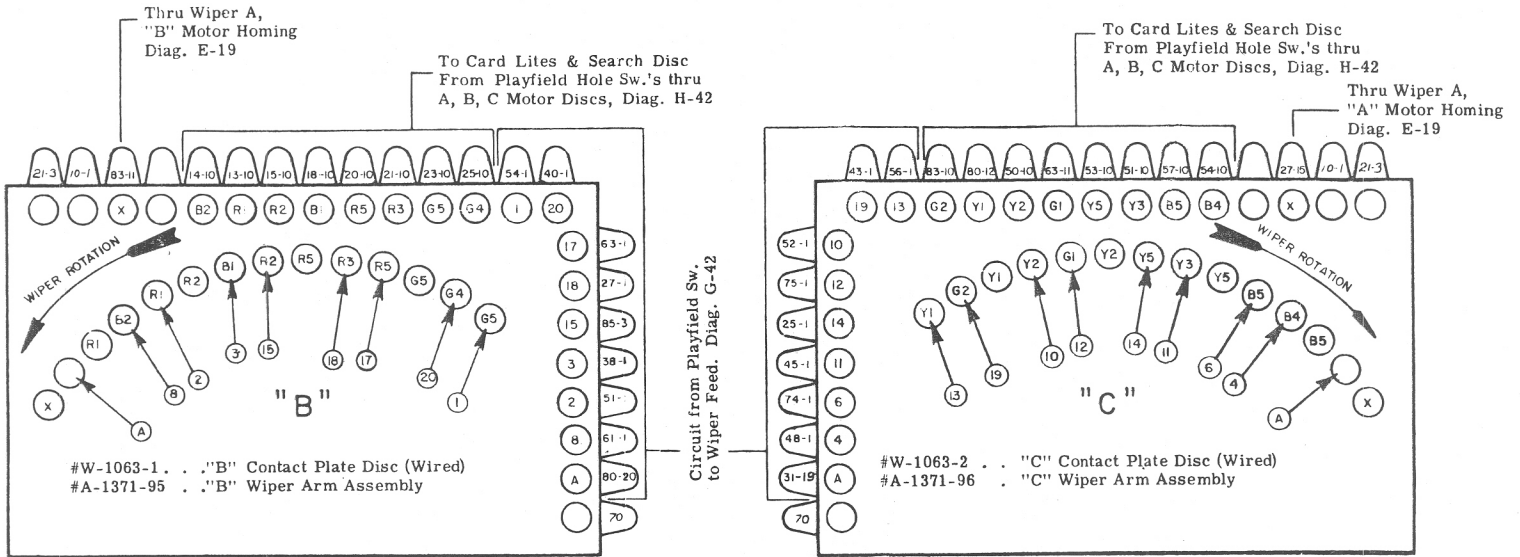

PARTS BREAKDOWN

Part No.	Description
AS-1809-10ND	Mystic Lines Unit (Complete)
E-119-457	Motor 25 R. P. M. ("A" Line)
E-119-353A	Motor 45 R. P. M. ("B" & "C" Lines)
AS-2659-87A	"B" & "C" Cam Relays (2 Req'd)
G-33-2800	Relay Coil
A-800-130A	"A" Line Cam & Hub Assembly
A-800-131A	"B" & "C" Line Cam & Hub Assy.
AS-982-535A	"A" Line Switch & Brkt. Assy.
AS-982-579A	"B" & "C" Line Sw. & Brkt. Assy.
A-2988A	1st Row Mystic Line Slat Assy.
A-2989A	2nd Row Mystic Line Slat Assy.
A-2990A	3rd Row Mystic Line Slat Assy.
A-2991A	4th Row Mystic Line Slat Assy.
A-2992A	5th Row Mystic Line Slat Assy.
M-1423A	Clear Plastic "Card Overlay
P-6588B	Front Plate (Red, Blue, Yellow, Green & Stars Plan)
E-125-47A	Light Bulb #1464 (20 Req'd)

CONTROL UNIT WINNER SEARCH POSITION CHART

CONTROL UNIT

WINNER SEARCH POS. CHART					
Red Wiper at Position	Wiper (1) Search Relay # 1	Wiper (2) Search Relay # 2	Wiper (3) Search Relay # 3	Wiper (4) Search Relay # 4	Wiper (5) Search Relay # 5
1					
2					
3					
4					
5					
6					
7					
8	Y5	R5	G5		
9					
10	B5	G5	Y5		
11					
12	B5	R5	G5		
13					
14	B5	Y5	R5		
15					
16	B5	Y5	R5	G5	
17					
18	G2	G3	G4		
19					
20	G1	G3	G4		
21					
22	G1	G2	G4		
23					
24	G1	G2	G3	G4	G5
25					
26	B2	B3	B4		
27					
28	B1	B3	B4		
29					
30	B1	B2	B4		
31					
32	B1	B2	B3	B4	B5
33					
34	R2	R3	R4		
35					
36	R1	R3	R4		
37					
38	R1	R2	R4		
39					
40	R1	R2	R3	R4	R5
41					
42	Y2	Y3	Y4		
43					
44	Y1	Y3	Y4		
45					
46	Y1	Y2	Y4		
47					
48	Y1	Y2	Y3	Y4	Y5
49					
50					

3 Star Game Winners

All 4 Star 300 - 600 Winners

Green Zone Winners

Blue Zone Winners

Red Zone Winners

Yellow Zone Winners

BINGO WINNERS READ ACROSS

MYSTIC LINES CHART REFERENCE

Y1	R1	G1	G2	G5*
B1	Y2	R2	R5*	G3
B2	Y5*	Y3	R3	G4
B5*	B3	B4	Y4	R4

MYSTIC LINES NUMERICAL REF. (INDEXED POSITION)

18	4	7	9	17*
11	8	12	6*	13
15	1*	20	2	19
16*	14	5	3	10

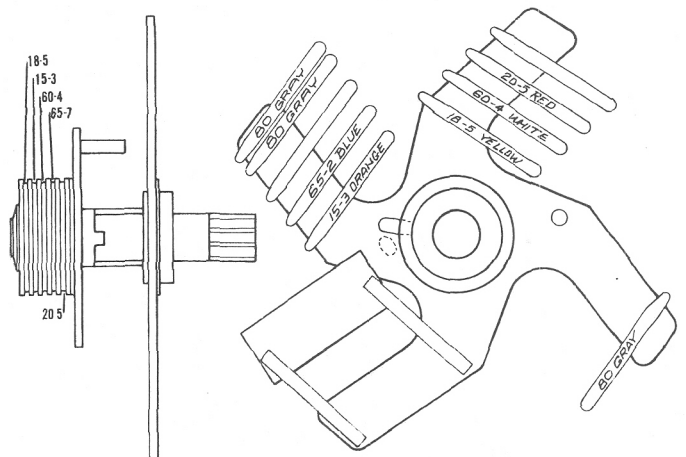

C. U. SEARCH DISC WIPER UNIT

CONTROL UNIT FUNCTION CHART

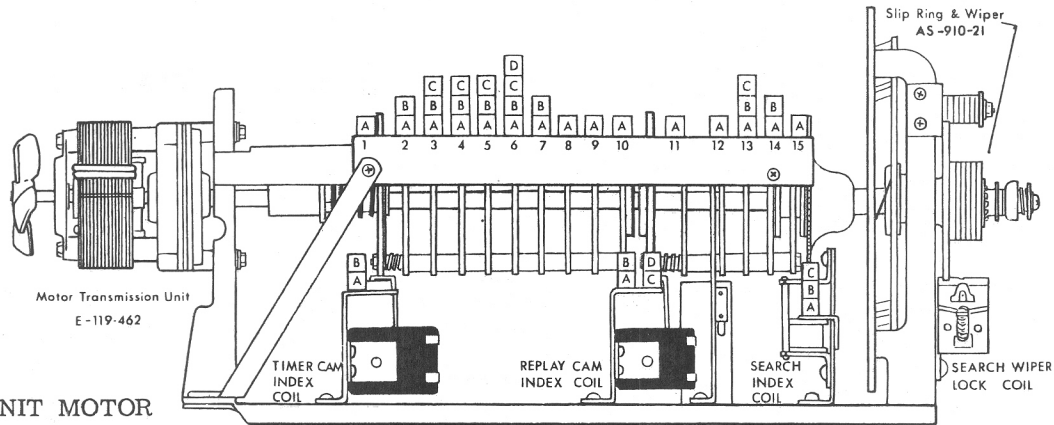

CONTROL UNIT MOTOR

E-119-462 50/60 Cy. 23.4 R.P.M. Domestic
 E-119-370 50 Cy. only 25 R.P.M. Belgium

The correct adjustment & synchronization of the Switches controlled by Cam No.'s 10A & 12 is vitally important to the Replay Counter Circuit. Out of adjustment Back Switches (12-C & 10A-A) can cause the four Replay Counters to become overloaded & burn out (affects the Printed Circuit Disc). Figure 3 shows these Cam Switches in a proper "Made" position. The Back Switches are adjustable. Note that the 12-C switch closes first & opens last. Cam Switch 12X is used for our testing purposes only.

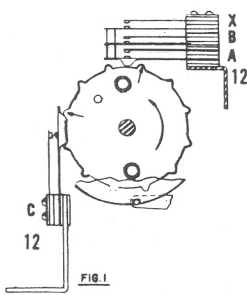

Replay Cam 12 shown in a normal indexed position. Switches 12 A, B, C are open.

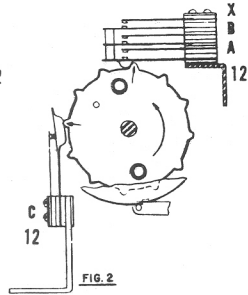

Cam 12 starting to rotate. Switches out of indexed pos. Switches A & B are open, Switch C is closed.

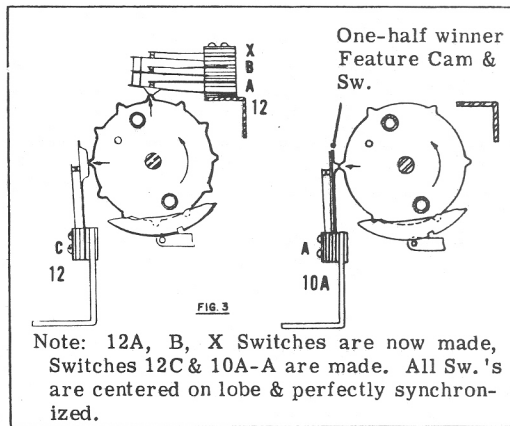

Note: 12A, B, X Switches are now made, Switches 12C & 10A-A are made. All Sw.'s are centered on lobe & perfectly synchronized.

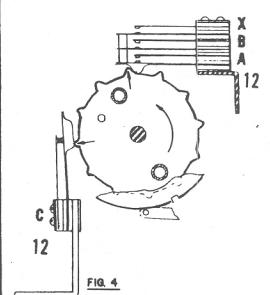

Cam #12 Switches A & B are now open again, however Switch C is still closed. After this cycle Cam & Switches return to the Fig. 1 position (open).

This entire sequence is repeated throughout the scoring cycle.

ADJUSTMENT PROCEDURES

Adjust Height and Switch so that the entire bent part of Switch Blade fits between Cam Lobes firmly on Cam & at Cam Center.

With Replay Cam Index Pin in Index Cam Notch. Replay Cam Index must be adjusted in so that switches are positioned between Cam Lobes as shown.

3/4 of Space from last Lobe

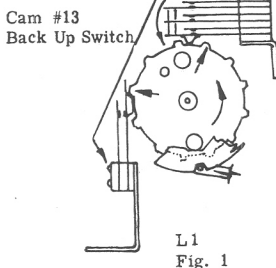

Replay Cams shown in their normal Indexed Positions. Switches are Open. Arrows point to Lobes that will actuate Switches.

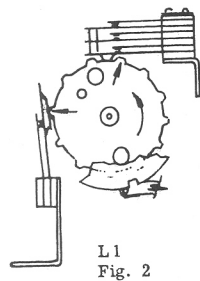

Replay Cams shown starting to Rotate they are now out of their Indexed Positions. Switches 1G, 2G & 3G are Open Switch L1 is now Open, Switch L1 is now Closed.

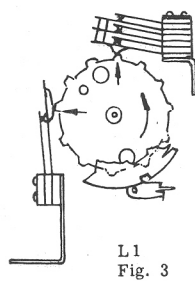

Switches 1G, 2G & 3G are now Closed. Switch L1 is still closed.

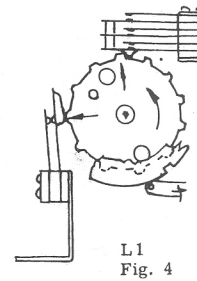

Switches 1G, 2G & 3G are now Open again. Switch L1 is still closed.

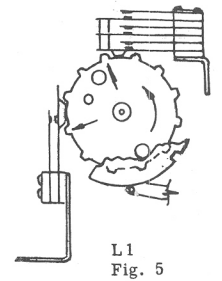

All Switches are now Open again. Same as in Fig. 1. This sequence is repeated thruout Replay Scoring Cycle.

ALWAYS GIVE MODEL AND PART NO. WHEN ORDERING SERVICE PARTS

CONTROL UNIT FUNCTION CHART

Switch/Coil	Part No.	Location on Diagram	Wire No.	Wire Color	Function
Control Unit Motor	E-119-462	D-1	60 P 50 P	Brown White	Energizes Control Unit Motor
#1 Pin Sw. N. C.	ASW-C2-28	D-8	Yellow 25-9	Yellow Blue-White	Opens Circuit to Multi-Play Relay Sw.
#2 Cam A. N. C.	ASW-C1-3	E-7	30 48-2	Yellow Green	Opens Circuit to Start Relay & Replay Register "O" Sw.
B. T.	ASW-C3-3	H-8	93-7 98-4 91-7	Grey-Yellow Grey-Black Grey-Red	93-7 Total Replay Meter Step-Up C.U. Cam 2, 91-7 Total Play Meter Step-Up C. U. Cam 2
#3 Cam A. N. O.	ASW-C1-3	E-12	20-4 21-3	Blue Blue-Red	Completes Circuit to Flash Index Coil
B. N. C.	ASW-C2-4	L-18	21-3 60-8	Blue-Red Brown	Open Circuit to Before 4th Trip Sw.
C. T.	ASW-C3-2	D-7	14-5 13-9 50 J	Red-Green Red-Yellow White	14-5 Circuit to Tilt Trip., 50J Wire to 15-13 for Multiplay or 10-5 for Single Play
Lug		D-7	10-5 50 J	Red White	Single Coin
Lug		D-7	15-13 50 J	Red-White White	Multi-Coin
#4 Cam A. N. O.	ASW-C1-3	D-8	27-9 80-2	Blue-Orange Black	Completes Circuit to Coin Meter
B. N. O.	ASW-C1-8	D-12	21-3 98-3	Blue-Red Grey-Black	Directs Circuit to Reflex Factor Index (Mixer), & Control Unit Cam #5
C. N. C.	ASW-C2-4	A-5	95-2 52-11	Grey-White White-Blue	Opens Circuit to Reflex Relay #1 Reflex Relay #2
#5 Cam A. N. O.	ASW-C1-3	D-12	98-3 41-5	Grey-Black Green-Red	Completes Circuit to Pulse Roving Cam (Mixer)
B. N. O.	ASW-C1-8	C-3	30 57-4	Yellow White-Orange	Completes Circuit to Coin Counter Step-Up Coil
C. N. O.	ASW-C1-8	E-3	30 78-4	Yellow Orange-Black	Completes Circuit to Anti-Cheat Relay Coil
#6 Cam A. N. O.	ASW-C1-52	K-26	83-3 98-7	Black-Yellow Grey-Black	Directs Circuit to Blue All Scores Relay & Green all Scores Relay
B. N. O.	ASW-C1-8	K-26	83-3 85-4	Black-Yellow Black-White	Directs Circuit to Yellow All Scores Relay & Red All Scores Relay
C. N. O.	ASW-C1-8	H-22	18-1 80-7	Red-Black Black	Completes Circuit to Selection Feature Step-Up Unit
D. N. O.	ASW-C1-8	H-19	95-1 58-2	Grey-White White-Black	Completes Circuit to Mystic Lines Step-Up Coil
#7 Cam A. N. O.	ASW-C1-3	K-27	20-7 90-2	Blue Grey	Directs Circuit to Red, Yel., Blue and Green Score Relay Switches
B. N. O.	ASW-C1-8	C-6	30 80-9	Yellow Black	Complete Circuit to Reflex Play Magnet Coil
Resistor	1800 OHM 2 WATT	C-6	80-9 30	Black Yellow	Resistor takes up surge as Coils Drop Out thus avoiding Coil hang up
#8 Cam N. O.	ASW-C1-3	K-26	91-4 90-2	Grey-Red Grey	Directs Circuit from 2 Step or 2 Step or 2 Step Relay to Red, Yel., Grn., & Blue Score Relay Sws.
#9 Cam N. O.	ASW-C1-3	K-27	93-2 90-2	Grey-Yellow Grey	Directs Circuit from 3 Step Relay to Red, Yel., Grn., & Blue Score Relay Sws.
#10 Cam N. O.	ASW-C1-3	H-7	30 36-13	Yellow Yellow-Brown	Directs Circuit to Multiplay Relay Sw. (Replay Register Step-Up Circuit)
#11 Cam N. O.	ASW-C1-4	G-12	63 90-1	Brown-Yellow Grey	Multiplier Circuit X12 Cam to one of the Win Relays or Alternator Unit depending on mode of Win Cycle
#12 Cam N. O.	ASW-C1-3	G-12	57 90-1	White-Orange Grey	Multiplier Circuit X6 Cam to one of the Win Relays or Alternator Unit depending on mode of Win Cycle

ALWAYS GIVE MODEL AND PART NO. WHEN ORDERING SERVICE PARTS

CONTROL UNIT FUNCTION CHART

Switch/Coil	Part No.	Location on Diagram	Wire No.	Wire Color	Function
#13 Cam A. N. O.	ASW-C1-3	H-9	71-14 27-17	Orange-Red Blue-Orange	Multiplier Circuit X1 in Win Cycle Steps Star Replay Counter & Alternator Alternator Unit
B. N. O.	ASW-C1-8	G-8	80 41-4	Black Green-Red	Directs Stepping Circuit to Step-Up Reflex Replay Magnet
C. N. O.	ASW-C1-8	G-11	90-1 45	Grey Green-White	Multiplier Circuit X2 Cam to one of the Win Relays or Alternator Unit Depending on mode of Win Cycle
Extra Sw. D. N. O.	ASW-C1-8		27 J	Blue-Orange	
Back Sw. Cam 13' N. O.	ASW-CIX-9	J-8	21-3 23-13	Blue-Red Blue-Yellow	Multiplier Circuit to Replay Cams Index Sw.
#14 Cam A. N. O.	ASW-C1-3	G-12	52 90-1	White-Blue Grey	Multiplier Circuit X4 Cam to one of the Win Relays or Alternator Unit depending on mode of Win Cycle
B. N. O.	ASW-C1-9	H-9	85-13 27-17	Black-White Blue-Orange	Multiplier Circuit X4 Cam to Star Replay Counter & Alternator Unit
#15 Cam N. C.	ASW-C1-4	L-17	74 31-11	Orange-Green Yellow-Red	Direct Win Search Feed Circuit for Search Disc and Score Discs
Search Wiper Lock - Coil	FD-30-1300	G-3	70 23-16	Orange Blue-Yellow	Energizes Search Wiper Lock Coil
Wiper Cam Sw. A. N. C.	ASW-C1-16	K-4	10-13 57-12	Red White-Orange	Opens Feed Circuit to Selection Feature Disc
B. N. C.	ASW-C1-17	B-7	53-13 13-16	White-Yellow Red-Yellow	Opens Circuit to Start Relay Sw.
C. N. C.	ASW-C1-17	G-3	52-9 23-16	White-Blue Blue-Yellow	Opens Circuit to Search Lock Magnet
Timer Cam Index Coil	BF-27-1250	A-9	70 61-7	Orange Brown-Red	Energizes Timer Cams Index Coil
A. N. O.	ASW-A1-43	E-2	20 P 60 P	Blue Brown	Directs Circuit to Control Unit Motor & Program Motor
B. N. C.	ASW-A2-18	D-8	98-6 27-9	Grey-Black Blue-Orange	Opens Circuit to Shutter Sw. & Coin Counter Sw.
Replay Cam Index Coil	CF-28-1025	G-7	70 40-19	Orange Green	Energizes Replay Cam Index Coil
A. N. O.	ASW-A1-11	L-17	31-11 74	Yellow-Red Orange-Green	Direct Win Search Feed Circuit for Search Disc and Score Discs
B. N. C.	ASW-A2-27	C-13	27-2 36-9	Blue-Orange Yellow-Brown	Opens Circuit to Timer Open at Top Sw. (Timer Step-Up Coil Circuit)
C. N. O.	ASW-A1-56	J-8	80 23-13	Black Blue-Yellow	Directs Feed Cir. to Search Disc & Win Circuit (See Diagram)
D. N. C.	ASW-A2-29	H-6	15-2 80	Red-White Black	Opens Circuit to Search Index Coil
Search Index Coil	EA-29-950	G-7	70 15-2	Orange Red-White	Energizes Search Index Coil
A. N. O.	ASW-A1-55	40-19	40-19 80	Green Black	Completes Circuit to Replay Cam Index Coil
B. N. C.	ASW-A2-28	B-7	51-8 53-13	White-Red White-Yellow	Opens Circuit to Search Wiper Cam Sw. (Start Relay Circuit)
Lug Lug Lug Lug			23-13 90-1 45 21-3	Blue-Yellow Grey Green-White Blue-Red	

ALWAYS GIVE MODEL AND PART NO. WHEN ORDERING SERVICE PARTS

CONTROL DISC ASSEMBLY

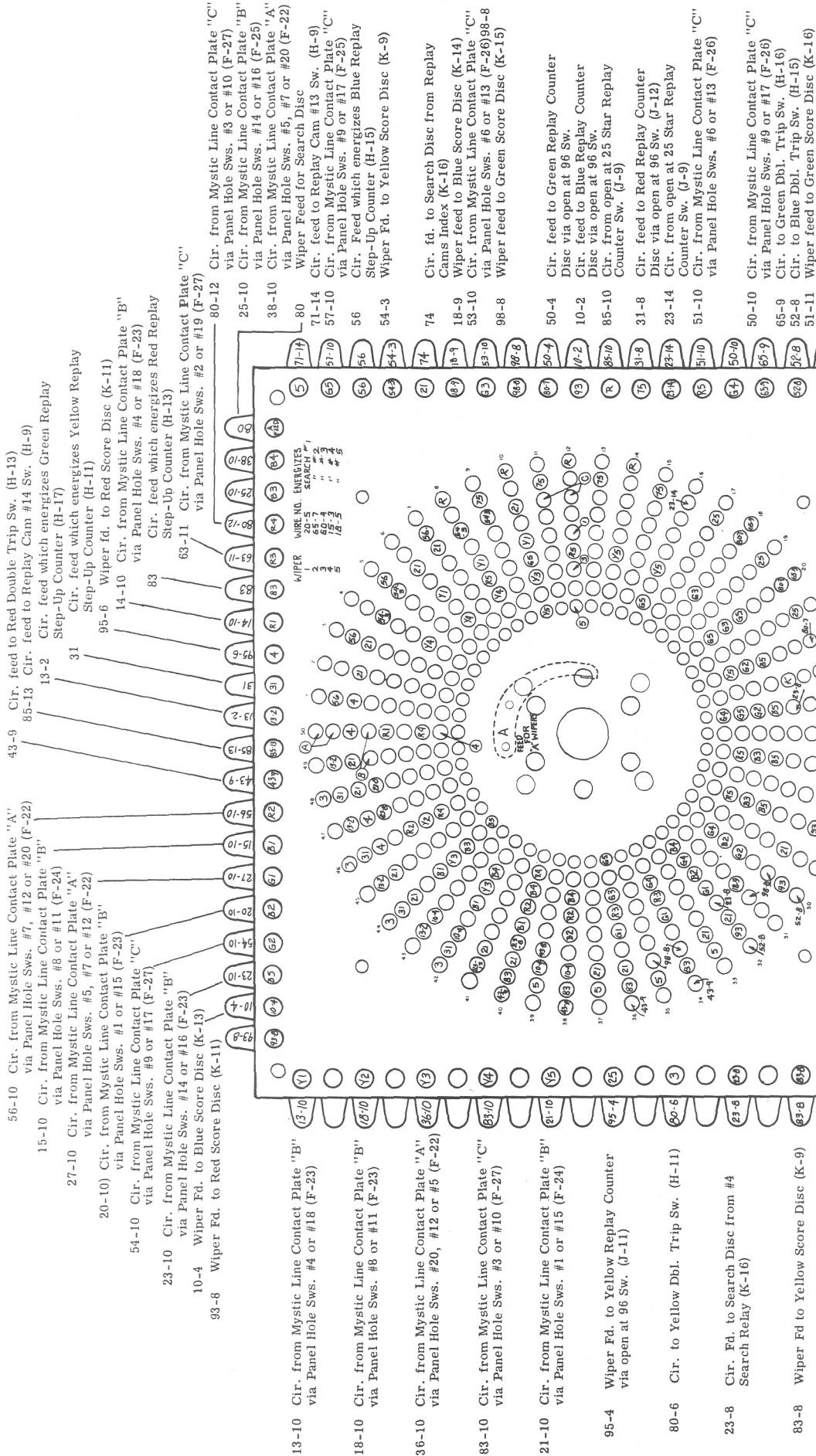

A5-1034-83
A-234-180
P-279-23

W-649-20

PROGRAM DISC ASSEMBLY

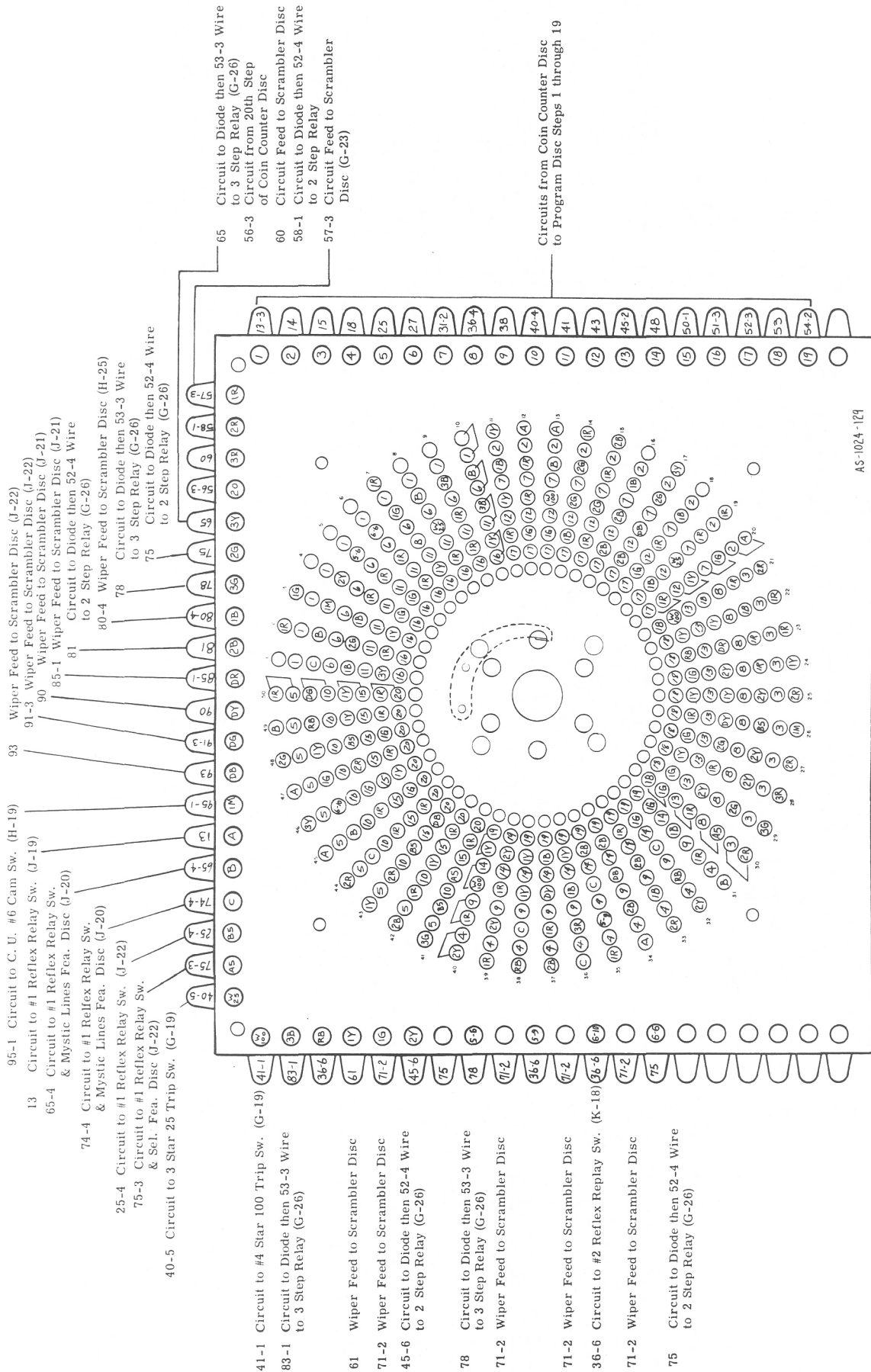

MIXER ASSEMBLY

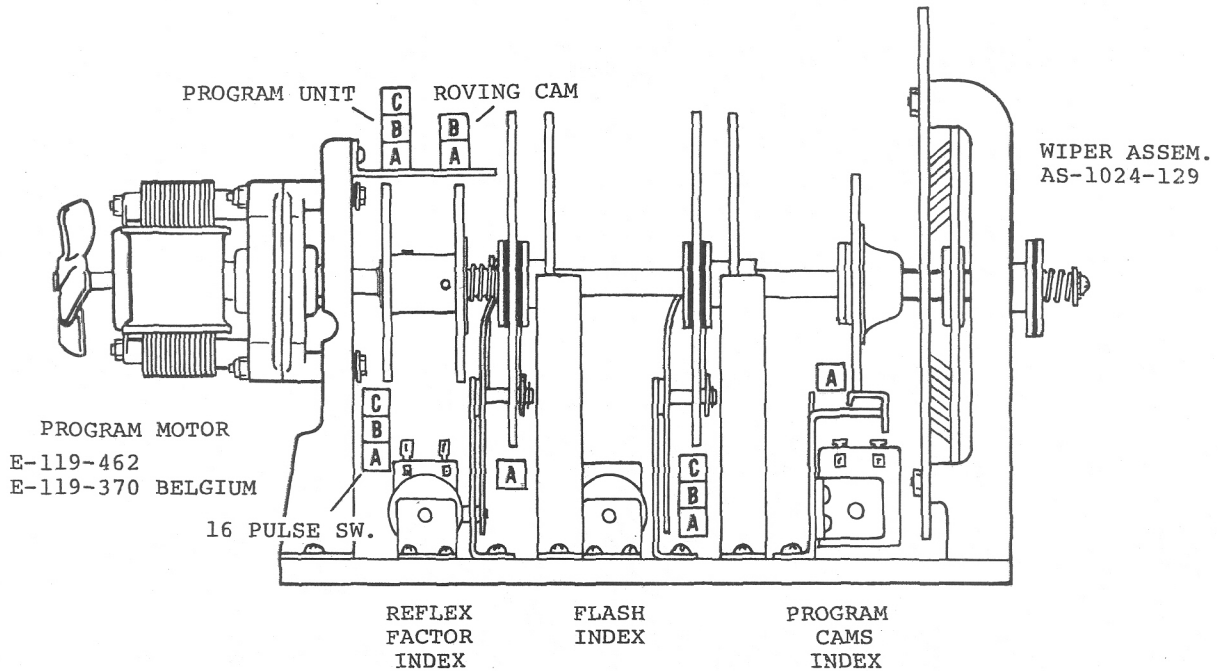

Switch/Coil	Part No.	Location on Diagram	Wire No.	Wire Color	Function
Program Motor	E-119-162	D-2	60 P 50 P	Brown White	Energizes Program Motor
Program Index	BF-27-1250	A-12	70 14 J	Orange Red-Green	Energizes Program Disc Coil
A. N. C.	ASW-A2-64	14-3	14 J 14-3	Red-Green Red-Green	Opens Circuit to Program Index
Flash Index	CR-28-1100	A-12	70 20-4	Orange Blue	Energizes Flash Index Coil
A. N. O.	ASW-A1-24	F-12	52-5 30	White-Blue Yellow	Completes Circuit to feed to flasher Disc
B. N. O.	ASW-C1-40	F-18	13-4 30	Red-Yellow Yellow	Completes Circuit Feed to Flasher Disc
C. N. O.	ASW-C1-40	F-18	81-6 30	Black-Red Yellow	Completes Circuit Feed to Flasher Disc
Reflex Factor Index	CR-28-1100	A-12	70 56-6	Orange White-Brown	Energizes Reflex Factor Index
A. N. O.	ASW-A1-124	C-12	98-3 41-5	Grey-Black Green-Red	Directs Circuit to Pulse Roving Cam (Mixer)
Program Unit	ASW-CIX-1	D-6	75-2 53-7	Orange-White White-Yellow	Circuit which Resets Replay Register Reset
A. N. O.	ASW-CIX-2	H-10	30 38-9	Yellow Yellow-Black	Sw. Directs Pulse Circuit to Alternator Unit
B. N. O.	ASW-CIX-2	F-15	23-11 48-12	Blue-Yellow Green-Black	Pulses Circuit to Select Now Lite and Press A, B, C Buttons Lite
Roving Cam	ASW-CIX-1	C-13	85-7 27-2	Black-White Blue-Orange	Pulses Circuit Timer Step-Up Coil
A. N. O.	ASW-C2-15	B-12	41-5 56-5	Green-Red White-Brown	Pulses Circuit Reflex Factor Index Coil
B. N. C.	ASW-CIX-1	H-20	58-2 61-2	White-Black Brown-Red	Pulses Circuit Mystic Lines Step-Up Unit
16 Pulse Sw.	ASW-CIX-2	H-22	80-7 81-2	Black Black-Red	Pulses Circuit Selection Feature Step-Up Unit
A. N. O.	ASW-CIX-2	F-14	20 13-11	Blue Red-Yellow	Pulses Circuit Insert Gate Lite & Panel Gate Lite
B. N. O.					

TRIP RELAY BANK-10

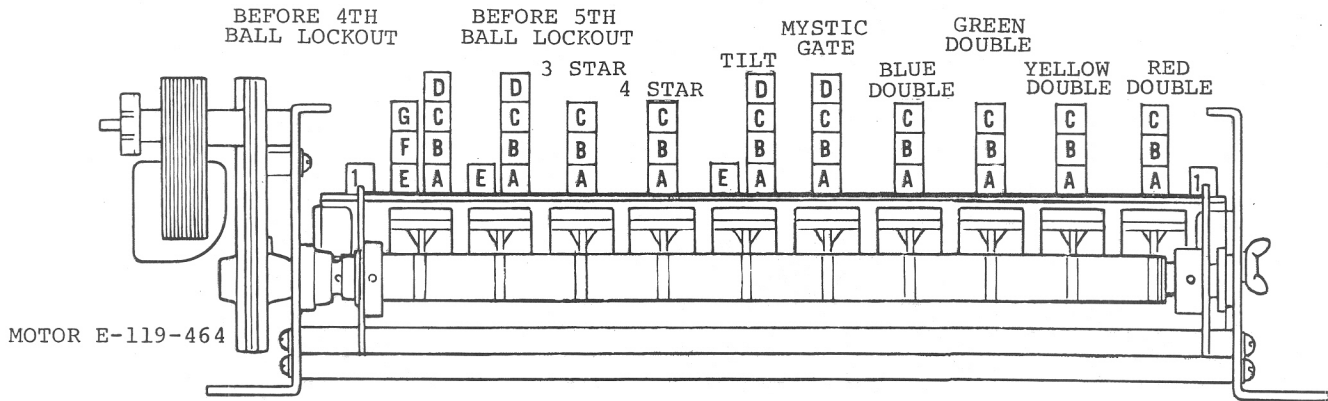

Switch/Coil	Part No.	Location on Diagram	Wire No.	Wire Color	Function
Double Red Trip Relay	D-27-425	G-21	70	Orange	Energizes Double Red Trip Relay
A. N. C.	ASW-B-2	H-21	51-4 51 J	White-Red White-Red	Opens Circuit to Coil
B. N. O.	ASW-B-1	F-19	14-17 30	Red-Green Yellow	Circuit to Double Red Lite
C. N. O.	ASW-B-1	J-13	43-9 78-14	Green-Yellow Orange-Black	Completes Circuit to Red Replay Step-Up Arm
Double Yellow Trip Relay	D-27-425	G-21	70	Orange	Energizes Double Yellow Trip Relay
A. N. C.	ASW-B-2	G-21	53-2 53 J	White-Yellow White-Yellow	Opens Circuit to Coil
B. N. O.	ASW-B-1	F-19	38-14 30	Yellow-Black Yellow	Circuit to Double Yellow Lite
C. N. O.	ASW-B-1	J-11	80-6 78-14	Black Orange-Black	Completes Circuit to Yellow Replay Step-Up Arm
Double Green Trip Relay	D-27-425	G-21	70	Orange	Energizes Double Green Trip Relay
A. N. C.	ASW-B-2	G-21	54-4 54 J	White-Green White-Green	Opens Circuit to Coil
B. N. O.	ASW-B-1	H-16	45-13 30	Green-White Yellow	Circuit to Double Green Lite
C. N. O.	ASW-B-1	J-17	65-9 78-14	Brown-White Orange-Black	Completes Circuit to Green Replay Step-Up Arm
Double Blue Trip Relay	D-27-425	G-21	70	Orange	Energizes Double Blue Relay
A. N. C.	ASW-B-2	G-21	56-4 56 J	White-Brown White-Brown	Opens Circuit to Coil
B. N. O.	ASW-B-1	F-20	74-11 30	Orange-Green Yellow	Circuit to Double Blue Lite
C. N. O.	ASW-B-1	H-15	52-8 78-14	White-Blue Orange-Black	Completes Circuit to Blue Replay Step-Up Arm
Mystic Gate	D-27-425	G-18	70	Orange	Energizes Mystic Gate Relay
A. N. C.	ASW-B-2	H-18	31 J 31-5 31 J	Yellow-Red Yellow-Red Yellow-Red	Opens Circuit to Relay
B. N. C.	ASW-B-2	D-16	74-7 30	Orange-Green Yellow	Opens Circuit to Rebound "Up" Sw. Located next to Mystic Gate Motor
C. N. O.	ASW-B-1	E-19	90-3 30	Grey Yellow	Completes Circuit to Mystic Gate Rebound Lite
D. N. O.	ASW-B-1	C-16	63-7 65-6	Brown-Yellow Brown-White	Completes Circuit to Golden Gate Lift Motor

ALWAYS GIVE MODEL AND PART NO. WHEN ORDERING SERVICE PARTS

Switch/Coil	Part No.	Location on Diagram	Wire No.	Wire Color	Function
Tilt	D-27-425	A-11	70 14-5	Orange Red-Green	Energizes Tilt Trip Relay
A. N. C.	ASW-B-2	F-22	10-1 51-7	Red White-Red	Opens Circuit to Anti-Cheat Relay
B. N. C.	ASW-B-2	D-2	60 P 30 P	Brown Yellow	Opens Circuit to Program Motor
C. T.	ASW-B-3	E-10	21-3 30 45-8	Blue-Red Yellow Green-White	Opens Circuit through 21-3, completes circuit to Shutter Cam 4 Closing Shutter if Open
D. T.	ASW-B-3	F-21	36-17 18-15 91-2	Yellow-Brown Red-Black Grey-Red	Open Cir. to A. C. Relay Sw. and Completes Circuit to Tilt Lite
E. N. O.	ASW-B-1	B-7	61-8 13-16	Brown-Red Red-Yellow	Completes Circuit to Start Relay
4 Star 100	D-27-425	G-19	70 41 J	Orange Green-Red	Energizes 4 Star Trip Relay
A. N. C.	ASW-B-2	G-19	41-1 41 J	Green-Red Green-Red	Opens Circuit to 4 Star Relay
B. N. O.	ASW-B-1	F-19	61-19 30	Brown-Red Yellow-Black	Completes Circuit to 4 Star Lite
C. N. O.	ASW-B-1	J-9	23-8 58-3	Blue-Yellow White-Black	Continues Circuit through "Open at 25 Star Replay Counter to Search Disc
Any 3 Star 25	D-27-425	G-19	70 40 J	Orange Green	Energizes 3 Star Relay
A. N. C.	ASW-B-2	H-19	40-5 40 J	Green Green	Opens Circuit to 3 Star Relay
B. N. O.	ASW-B-1	F-19	50-8 30	White Yellow	Completes Circuit to 3 Star Lite
C. N. O.	ASW-B-1	K-9	74 57-1	Orange-Green White-Orange	Completes Circuit to Open at 25 Star Replay Counter Sw.
Select Before 5th	D-27-425	G-3	70 75 J	Orange Blue-White	Energizes Select Before 5th Relay
A. N. C.	ASW-B-1	G-3	75-5 75 J	Orange-White Orange-White	Opens Circuit to Before 5th Relay
B. N. C.	ASW-B-1	J-4	98-2 90-4	Grey-Black Grey	Opens Circuit to Mystic Lines Disc
C. N. C.	ASW-B-2	F-15	23-5 74-8	Blue-Black Orange-Green	Opens Circuit to Selection Feature Disc
D. N. C.	ASW-B-2	D-11	25-8 14-3	Blue-White Red-Green	Opens Circuit to Program Index Sw. Located on Index Coil on Mixer
E. N. O.	ASW-B-2	D-13	50-5 85-8	White Black-White	Completes Circuit to 1 Pulse Mixer Cam making the Timer Step-Up Operation possible, also directs Circuit to "R" Button
F. N. O.	ASW-B-2	F-15	48-12 53-12	Green-Black White-Yellow	Completes Circuit, flashing Select Now Lite
Select Before 4th	D-27-425	G-3	70 83 J	Orange Black-Yellow	Energizes before 4th Trip Relay
A. N. C.	ASW-B-1	H-3	83-6 83 J	Black-Yellow Black-Yellow	Opens Circuit to Before 4th Relay
B. N. C.	ASW-B-1	F-15	27-4 57-5	Blue-Orange White-Orange	Opens Circuit to Flashing Select Now Lite
C. N. C.	ASW-B-1	L-18	60-8 18-7	Brown Red-Black	Opens Circuit to Scrambler Disc
D. N. C.	ASW-B-2	K-3	95-3 90-4	Grey-White Grey	Opens Feed Circuit to Mystic Lines Disc
E. N. O.	ASW-B-2	K-3	10-13 53-18	Red White-Yellow	Complete Circuit to "R" Button making operable for Search
F. N. O.	ASW-B-2	E-13	36-2 43-2	Yellow-Brown Green-Yellow	Completes Circuit to Lifter Cam #2 Sw.
G. N. O.	ASW-B-2	E-11	21-3 25-8	Blue-Red Blue-White	Completes Circuit to Before 5th Trip, Program Index Circuit
Carryover N. O.	ASW-B-20	B-4	30 90-10	Yellow Grey	Completes Circuit to Trip Bank Motor
Trip Bank Motor	E-119-464	A-4	70 90-10	Orange Grey	Energizes Trip Bank Motor

ALWAYS GIVE MODEL AND PART NO. WHEN ORDERING SERVICE PARTS

SEARCH RELAY BANK 5

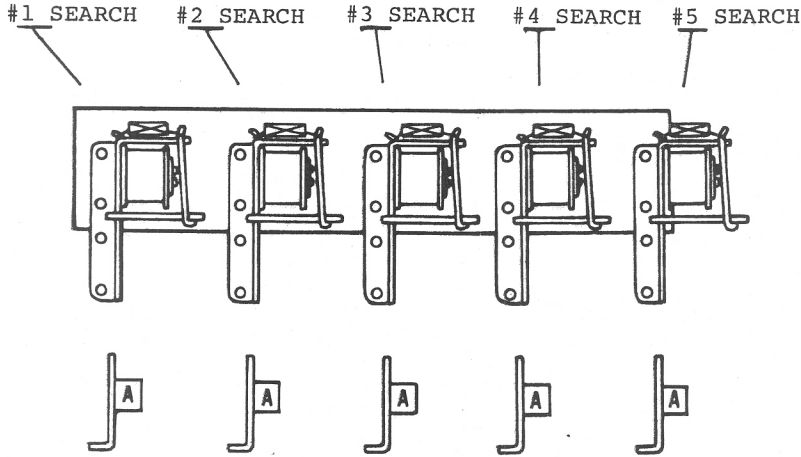

Note: A #E-105-64B Resistor is installed on each Coil.

SWITCH CODE

N. C. Normally Closed
 N. O. Normally Open
 M. B. B. Make Before Break
 S. P. D. T. . . . Single Pole Double Throw

Switch/Coil	Part No.	Location on Diagram	Wire No.	Wire Color	Function
#1 Search Relay	Coil G-28-850	D-25	50-9 20-5	White Blue	Energizes Search Relay #1
A. N. O.	ASW-R1-8	L-15	15-5 38-11	Red-White Yellow-Black	Directs Circuit to Search Relay #2 Sw. for possible Replay Cycle
#2 Search Relay	Coil G-28-850	D-25	50-9 65-7	White Brown-White	Energizes Search Relay #2
A. N. O.	ASW-R1-8	L-16	38-11 36-11	Yellow-Black Yellow-Brown	Directs Circuit to Search Relay #3 Sw. for possible Replay Cycle
#3 Search Relay	Coil G-28-850	D-26	W 60-4	White Brown	Energizes Search Relay #3
A. N. O.	ASW-R1-8	L-16	31-11 36-11	Yellow-Red Yellow-Brown	Directs Circuit to Replay Cam Index Sw. & Replay Cam #15 Sw.
#4 Search Relay	Coil G-28-850	D-27	50-9 15-3	White Red-White	Energizes Search Relay #4
A. N. O.	ASW-R1-8	K-16	74 23-8	Orange-Green Blue-Yellow	Directs Circuit to Search Disc & Search Relay Sw. #5
#5 Search Relay	Coil G-28-850	D-27	50-9 18-5	White Red-Black	Energizes Search Relay #5
A. N. O.	ASW-R1-8	K-16	61-3 23-8	Brown-Red Blue-Yellow	Directs Feed Circuit to all Score Discs

ALWAYS GIVE MODEL AND PART NO. WHEN ORDERING SERVICE PARTS

7 RELAY BANK

ALL SCORES #3 STEP #2 STEP BLUE GREEN YELLOW RED
SCORE SCORE SCORE SCORE

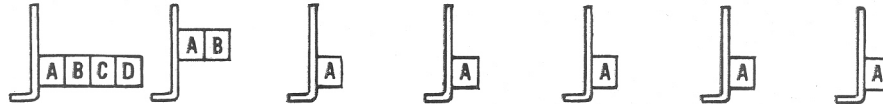
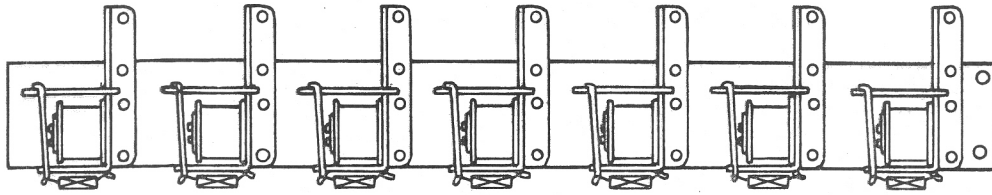

Switch/Coil	Part No.	Location on Diagram	Wire No.	Wire Color	Function
Red Score Relay	G-32-2500	G-23	70 54-5	Orange White-Green	Energized via scrambler disc
A. N. O.	ASW-R1-7	J-27	90-2 15-6	Grey Red-White	Completes Circuit to Red Score Step-Up Unit.
Yellow Score Relay	G-32-2500	G-23	70 56-5	Orange White-Brown	Energized via Scrambler Disc
A. N. O.	ASW-R1-7	J-27	90-2 18-2	Grey Red-Black	Completes Circuit to Yellow Score Step-Up Unit
Green Score Relay	G-32-2500	G-24	70 57-6	Orange White-Orange	Energized via Scrambler Disc
A. N. O.	ASW-R1-7	J-28	90-2 20-2	Grey Blue	Completes Circuit to Green Score Step-Up Unit
Blue Score Relay	G-32-2500	G-25	70 58-5	Orange White-Black	Energized via Scrambler Disc
A. N. O.	ASW-R1-7	J-28	90-2 23-6	Grey Blue-Yellow	Completes Circuit to Blue Score Step-Up Unit
#2 Step-Relay	G-32-2500	G-26	70 52-4	Orange White-Blue	Energized via Diode Fed from 81 via Program Disc
A. N. O.	ASW-R1-7	K-27	21-3 91-4	Blue-Red Grey-Red	Completes Circuit to Control Unit Cam #8
#3 Step-Relay	G-32-2500	G-26	70 53-3	Orange White-Yellow	Energizes 3 Step Relay
A. N. O.	ASW-R1-7	K-27	93-2 21-3	Grey-Yellow Blue-Red	Completes Circuit to Control Unit Cam #9
B. N. O.	ASW-R1-3	K-27	91-4 21-3	Grey-Red Blue-Red	Completes Circuit to Control Unit Cam #8
All Score Relay	G-31-1500	G-26	70 85-4	Orange Black-White	Energizes all Score Relay
A. N. O.	ASW-R1-7	H-26	15-6 85-4	Red-White Black-White	Completes Circuit to Red Score Step-Up Unit
B. N. O.	ASW-R1-3	H-26	18-2 85-4	Red-Black Black-White	Completes Circuit to Yellow Score Step-Up Unit
C. N. O.	ASW-R1-3	H-26	20-2 85-4	Blue Black-White	Completes Circuit to Green Score Step-Up Unit
D. N. O.	ASW-R1-3	H-26	23-6 85-4	Blue-Yellow Black-White	Completes Circuit to Blue Score Step-Up Unit

ALWAYS GIVE MODEL AND PART NO. WHEN ORDERING SERVICE PARTS

5 RELAY BANK

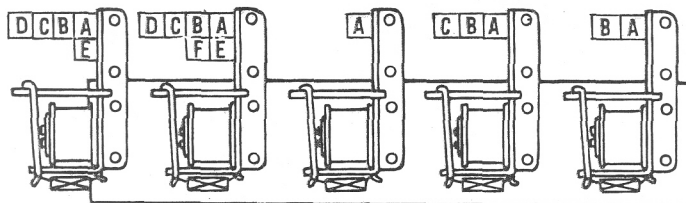

#2 REFLEX #1 REFLEX #2 MULTI-WIN #1 MULTI-WIN BALL-LIFT

Switch/Coil	Part No.	Location on Diagram	Wire No.	Wire Color	Function
Ball Lift Relay	G-32-2500	A-11	70 81-3	Orange Black-White	Energizes Ball Lifter Relay
A. N. O.	ASW-R1-3	D-15	36-3 91-1	Yellow-Brown Grey-Red	Manual Button Sw. Direct Circuit through (Timer Open at "O" Sw.) to Ball Lift Motor
B. N. C.	ASW-R2-5	G-3	78-7 75-5	Orange-Black Orange-White	Opens Circuit to before 5th Trip Sw.
#1 Mult. Relay	G-33-2800	G-11	70 78-14	Orange Orange-Black	Energizes Multiple Win Relay #1
A. N. C.	ASW-R2-5	G-12	90-1 70	Grey Orange	Bypass of Multiple Win Relay #2
B. N. C.	ASW-R2-5	G-12	90-1 70	Grey Orange	Bypass of Multiple Win Relay #2
C. N. C.	ASW-R2-5	G-10	80-16 43-15	Black Green-Yellow	Opens Circuit to Alternator Homing Switch
#2 Mult. Relay	G-32-2500	G-12	70 90-1	Orange Grey	Energizes Multiple Win Relay #2
A. N. O.	ASW-R1-3	H-11	78-14 75-6	Orange-Black Orange-White	Completes Circuit to Alternator Unit Coil
#1 Reflex Relay	G-32-2500	A-5	70 52-11	Orange White-Blue	Energizes #1 Reflex Relay
A. N. O.	ASW-R1-3	J-20	65-4 63-6	Brown-White Brown-Yellow	Directs Circuit from "B" fea. on Disc through Mystic Lines fea. disc to Mystic Lines Step-Up Unit
B. N. O.	ASW-R1-3	J-21	74-4 71-3	Orange-Green Orange-Red	Directs Circuit from "C" Fea. on Program Disc through Mystic Lines fea. Disc to Mystic Lines Step-Up Unit
C. N. O.	ASW-R1-3	J-23	75-3 78-2	Orange-White Orange-Black	Direct Circuit through Selection Fea. Disc to Selection Fea. Step-Up Unit
D. T.	ASW-R3-6	K-26	91-4 21-3 20-7	Grey-Red Blue-Red Blue	Via 91-4 Directs Circuit to C. U. Cam 8, Via 95-4 directs Cir. to C. U. Cam 7
E. T.	ASW-R3-6	J-19	95-1 13 98	Grey-White Red-Yellow Grey-Black	Via 98 directs Circuit to Mystic Lines Lines Fea. Disc, via 95-1 Cir. to C. U. Cam 6
F. T.	ASW-R3-6	J-23	18-1 25-4 23-4	Red-Black Blue-White Blue-Yellow	Stepping Fea. Step-Up when #1 & #2 Reflex Relay are not Energized.
#2 Reflex Relay	G-32-2500	A-5	70 52-11	Orange White-Blue	Energizes #2 Reflex Relay
A. T.	ASW-R3-6	H-21	18-1 43-4 51-4	Red-Black Green-Yellow White-Red	Directs Circuit to either Double Red Trip or Selection Fea. Step-Up Unit
B. T.	ASW-R3-6	H-21	18-1 45-3 53-2	Red-Black Green-White White-Yellow	Directs Circuit to either Double Yellow Trip or Selection Fea. Step-Up Unit
C. T.	H-21	H-21	18-1 48-7 54-4	Red-Black Green-Black White-Green	Directs Circuit to either Double Grn. Trip or Selection Fea. Step-Up Unit
D. T.	ASW-R3-6	H-21	18-1 50-3 56-4	Red-Black White White-Brown	Directs Circuit to either Double Red Trip or Selection Fea. Step-Up Unit
E. T.	ASW-R3-6	K-18	18-1 36-6 31-5	Red-Black Yellow-Brown Yellow-Red	Directs Circuit through 18-1 to Selection Fea. Step-Up, 31-5 to Golden Gate Trip

ALWAYS GIVE MODEL AND PART NO. WHEN ORDERING SERVICE PARTS

4 RELAY BANK

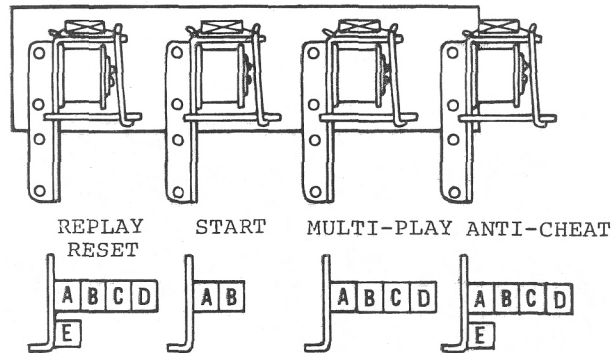

Switch/Coil	Part No.	Location on Diagram	Wire No.	Wire Color	Function
Replay Reset	G-1500-30	A-6	70 75-2	Orange Orange-White	Energizes Replay Reset Coil
A. N. O.	ASW-R1-3	D-6	56-2 75-2	White-Brown Orange-White	Directs Circuit towards Replay Reset Relay and Replay Reg. Reset A-6
B. N. O.	ASW-R1-3	E-1	20P 60P	Blue Brown	Completes Circuit to C. U. Motor and Program Motor
C. N. C.	ASW-R2-5	H-7	30 50-11	Yellow White	Opens Circuit to Key Sw.
D. N. C.	ASW-R2-5	C-7	10-5 61-8	Red Brown-Red	Opens Circuit to Tilt Trip Sw. Coin Counter Open at Top Sw. & Shutter Open when Open Sw.
E. T.	ASW-R3-6	B-6	80-9 98-5 53-7	Black Grey-Black White-Yellow	98-5 Circuit to Multi-Play Relay Sw. 80-9 Circuit to Reflex Play Magnet
Start Relay	G-2500-32	A-7	70 98-10	Orange Grey-Black	Start Relay Energized through Key Sw. Start Circuit & Coin Sw.
A. N. O.	ASW-R1-8	C-9	13-16 48-2	Red-Yellow Green-Black	Directs Circuit to Start Relay & Timer Cams Index
B. N. O.	ASW-R1-3	A-9	13-16 10-10	Red-Yellow Red	Directs Circuit to Shutter Cam #5 Sw.
Multi-Play	G-2500-32	A-8	70 15-13	Orange Red-White	Energizes Multiplay Relay Coil
A. N. O.	ASW-R1-8	D-8	25-9 15-13	Blue-White Red-White	Completes Circuit to Multi-Play Relay
B. N. O.	ASW-R1-3	C-7	10-5 27-9	Red Blue-Orange	Completes Circuit to Replay Reset Relay Sw.
C. N. C.	ASW-R2-5	B-6	45-9 98-5	Green-White Grey-Black	Opens Circuit to Replay Register Reset
D. T.	ASW-R3-6	H-7	41-4 75-9 36-13	Green-Red Orange-White Yellow-Brown	36-13 Circuit from C. U. Cam 10 to Replay Register Step-Up, 41-4 Circuit from C. U. Cam 13 1X
Anti-Cheat Relay	G-32-2500 Unwrapped	A-3	70 78-4	Orange Orange-Black	Energizes Anti-Cheat Relay Coil
A. N. O.	ASW-R1-8	D-3	30 78-4	Yellow Orange-Black	Completes Circuit to Anti-Cheat Relay
B. N. O.	ASW-R1-3	F-22	51-7 80-1	White-Red Black	Circuit Remains Dead until Relay pulls in
C. N. C.	ASW-R2-5	D-10	14-14 30	Red-Green Yellow	When Game is Activated, the Sw. directs Circuit to close Shutter
D. T.	ASW-R3-6	D-7	75-2 56-2 50-2	Orange-White White-Brown White	75-2 Resets Register via 16 pulse Cam; 50-2 Energizes play circuit Red Button
E. T.	ASW-R3-6	F-21	91-2 36-17 40	Grey-Red Yellow-Brown Green	91-2 Circuit to Tilt Lite 40 Energizes Lite Circuit

ALWAYS GIVE MODEL AND PART NO. WHEN ORDERING SERVICE PARTS

REPLAY COUNTERS RED, YEL., BLUE & GRN.

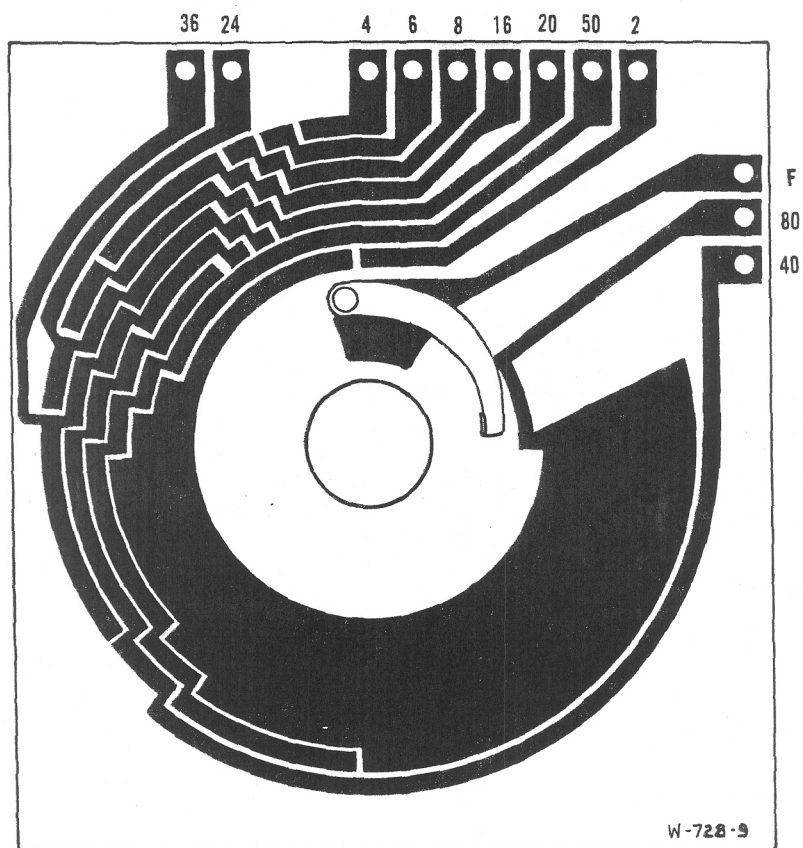

LUG	YELLOW REPLAY COUNTER	RED REPLAY COUNTER	BLUE REPLAY COUNTER	GREEN REPLAY COUNTER
50	57-2	40-3	54-6	60-9
80	50-6	27-8	61-6	61-9
F	23	71	91	54
36	51-2	23-3	74-3	90-8
24	41-2	20-3	65-3	13-1
20	40-2	10-3	63-3	27-6
16	23-2	85-2	60-3	45-12
8	93-1	83-2	48-3	40-9
6	81-1	74-2	43-3	36-14
4	78-1	60-2	41-3	41-9
40	52-2	25-3	80-3	57-9
2	60-6	21-16	75-11	63-12

ALWAYS GIVE MODEL AND PART NO. WHEN ORDERING SERVICE PARTS

REPLAY COUNTERS RED, YEL., BLUE & GRN.

Switch/Coil	Part No.	Location on Diagram	Wire No.	Wire Color	Function
Red Replay Step-Up	B-25-925	H-13	83	Black-Yellow	Energizes Red Step-Up Coil
Reset	C-28-1100	B-17	23-12 70 85 J	Blue-Yellow Orange Black-White	Energizes Red Reset Coil
Open at "O" N. O.	ASW-U1	B-17	85-5 85 J	Black-White Black-White	Opens Circuit to Reset Coil
Open at "96" N. C.	ASW-U2	J-12	31-8 71	Yellow-Red Orange-Red	Opens Circuit to Search Disc De-Activating Replay Count
Step-Up Arm N. O.	ASW-U1-9	H-13	78-14 75-6	Orange-Black Orange-White	Completes Circuit to Multiple Win Relay #1
Yellow Replay Step-Up	B-25-925	H-11	31 71-19	Yellow-Red Orange-Red	Energizes Yellow Step-Up Coil
Reset	C-28-1100	B-17	70 85 J	Orange Black-White	Energizes Yellow Reset Coil
Open at "O" N. O.	ASW-U1	B-17	85-5 85 J	Black-White Black-White	Opens Circuit to Reset Coil
Open at "96" N. C.	ASW-U2	J-11	95-4 23	Grey-White Blue-Yellow	Opens Circuit to Search Disc De-Activating Replay Count
Step-Up Arm N. O.	ASW-U1-9	H-11	78-14 75-6	Orange-Black Orange-White	Completes Circuit to Multiple Win Relay #1
Green Replay Step-Up	B-25-925	H-17	13-2 90-7	Red-Yellow Grey	Energizes Green Step-Up Coil
Reset	C-28-1100	B-17	70 85 J	Orange Black-White	Energizes Green Reset Coil
Open at "O" N. O.	ASW-U1	B-17	85-5q 85 J	Black-White Black-White	Opens Circuit to Reset Coil
Open at "96" N. C.	ASW-U2	J-17	50-4 54	White White-Green	Opens Circuit to Search Disc De-Activating Replay Count
Step-Up Arm N. O.	ASW-U1-9	H-17	78-14 75-6	Orange-Black Orange-White	
Blue-Replay Step-Up	B-25-925	H-15	56 36-1	White-Brown Yellow-Brown	Energizes Blue Step-Up Coil
Reset	C-28-1100	B-17	70 85 J	Orange Black-White	Energizes Blue Reset Coil
Open at "O" N. O.	ASW-O1	B-17	85-5 85 J	Black-White Black-White	Opens Circuit to Reset Coil
Opens at "96" N. C.	ASW-U2	J-15	91 10-2	Grey-Red Red	Opens Circuit to Search Disc De-Activating Replay Count
Step-Up Arm N. O.	ASW-U1-9	H-15	78-14 75-6	Orange-Black Orange-White	
Replay Register Step-Up	A-26-1100	G-7	70 80-19	Orange Black	Energizes Register Step-Up Coil
Reset	A-27-1100	A-6	70 45-9	Orange	Energizes Register Reset Coil
A. T.	ASW-U3-6	E-7	56-2 48-2 27-9	White-Brown Green-Black Blue-Orange	27-9 Circuit to Coin Sw., Timer Cam Index and C.U. Cam 4., 56-2 Circuit to Replay Reset Relay Sw. and A. C. Relay
B. N. O.	ASW-U1-6	D-7	63-2 10-5	Brown-Yellow Red	Completes Circuit to Replay Reset Relay, Start Relay Circuit

ALWAYS GIVE MODEL AND PART NO. WHEN ORDERING SERVICE PARTS

COIN COUNTER DISC

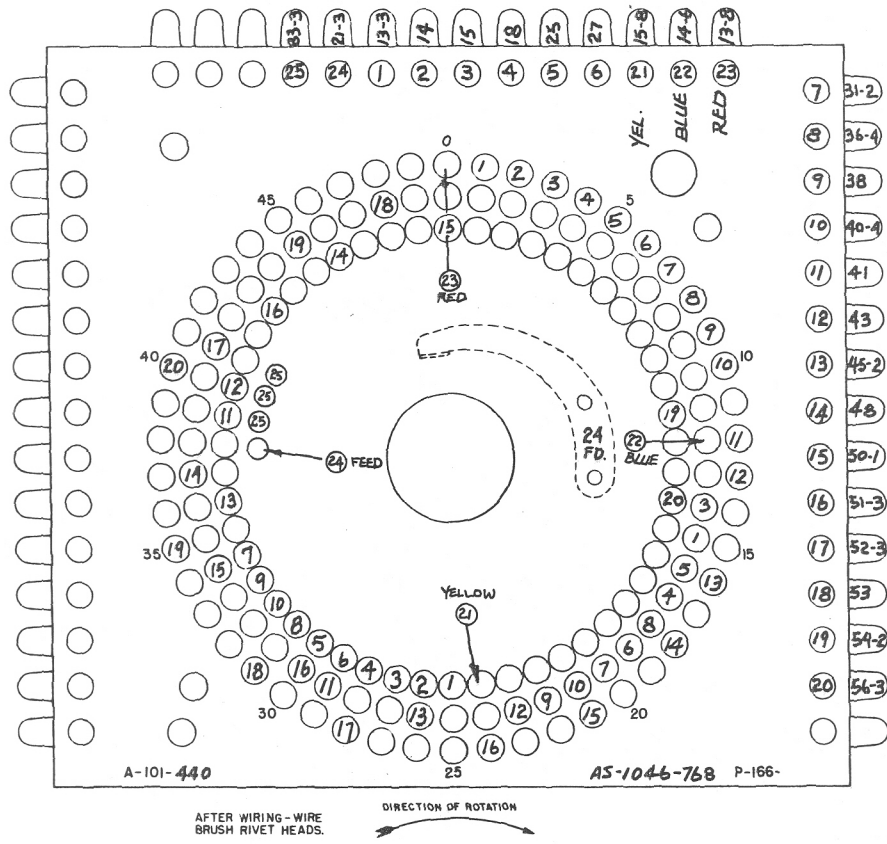

COIN COUNTER

- 83-3 Circuit to C. U. Cam #6 Sw.
- 21-3 Feed
- 13-3 to 27 Circuits to Program Disc

FEEDS

- 31-2 to 56-3 Circuits to Program Disc

ALWAYS GIVE MODEL AND PART NO. WHEN ORDERING SERVICE PARTS

TIMER DISC

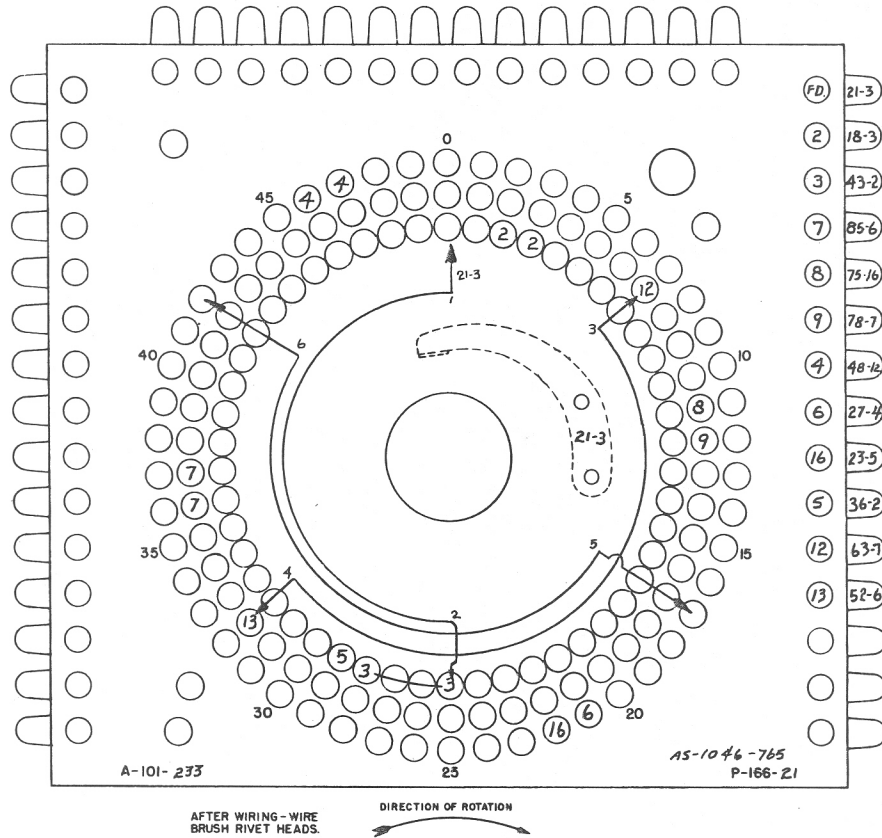

- | | |
|--|---|
| (2) Feed, 25 Step Unit
Directs Cir. to Shutter Motor Cam #4 Sw. Closed when Open (D-14) | (6) Cir. to Select Before 4th Lite |
| (3) Cir. to Lifter Cam #2 Sw. | (16) Cir. to Select Before 5th Lite |
| (7) Cir. from Lifter Cam #1 Sw. | (5) Cir. to Before 4th Trip Sw. (F-18) |
| (8) Cir. to Ball Trough Sw. (D-23) | (12) Safety Circuit Lifts Ball Gate when Game is Coined (E-6) |
| (9) Cir. to Ball Lift Relay Sw. (C-23) | (13) Cir. to Shutter Motor Cam Closed when Open (E-61) |
| (4) Cir. to 16 Pulse Cam
Flashes Select Now' Lite | Gate when Game is Coined (E-61) |

Switch/Coil	Part No.	Location on Diagram	Wire No.	Wire Color	Function
Timer Step-Up	B-25-925	A-12	70 36J	Orange Yellow-Brown	Energizes Timer Step-Up Coil
Timer Reset	C-28-1100	A-13	70 71-8	Orange Orange-Red	Energizes Timer Reset Coil
Open At 'O' A. N. O.	ASW-U2	B-15	91-1 38-3	Grey-Red Yellow-Black	On Second Step after Timer is Activated directs Circuit to Ball Lift Motor.
Open At 'O' B. N. O.	ASW-U2-2	E-14	90-9 30	Grey Yellow	Directs Circuit to Shutter Cam #5 Sw. Closed when Open

ALWAYS GIVE MODEL AND PART NO. WHEN ORDERING SERVICE PARTS

TIMER 462 KIT

Addition of Switch to Timer Unit opens Reset Circuit at "O", without Sw. holding "R" Button may cause Reset Coil to burn out.

Kit Mounting and Adjustment Procedures:

1. Mount the Switch and Brkt. Assy. (AS-982-1097) between the Timer Unit Disc and Base Plate Assemblies with (2) SF-PP-00832-1106 Self Tapping Screws as indicated (A).
2. Reset the Reset Coil and Adjust the new Sw. :
 - A. Adjust the bottom Fishpaper Leaf and Idler Leaf of the Sw. & Brkt. Assy. to rest on the Reset Pawl Assy. (B)
 - B. Adjust the Sw. Lifter (C) to rest on the Lower Idler Leaf.
 - C. Adjust the Sw. Contacts (D) to be opened at Reset Rest Position and close on the 1st Position, so that when the Contacts will Open or Close, there will be follow-thru of the Contacts without excess Bowing of the Switch Blades.
3. Replace the old Cable 71-8 (Orange-Red) Wire from the Reset Coil Lug with the new Orange-Red Jumper Wire from the new Sw. as indicated.
4. Cut for length the loose, Orange-Red Jumper Wire; and then solder and tape that Jumper Wire to the now loose 71-8 (Orange-Red) Wire from the cable.

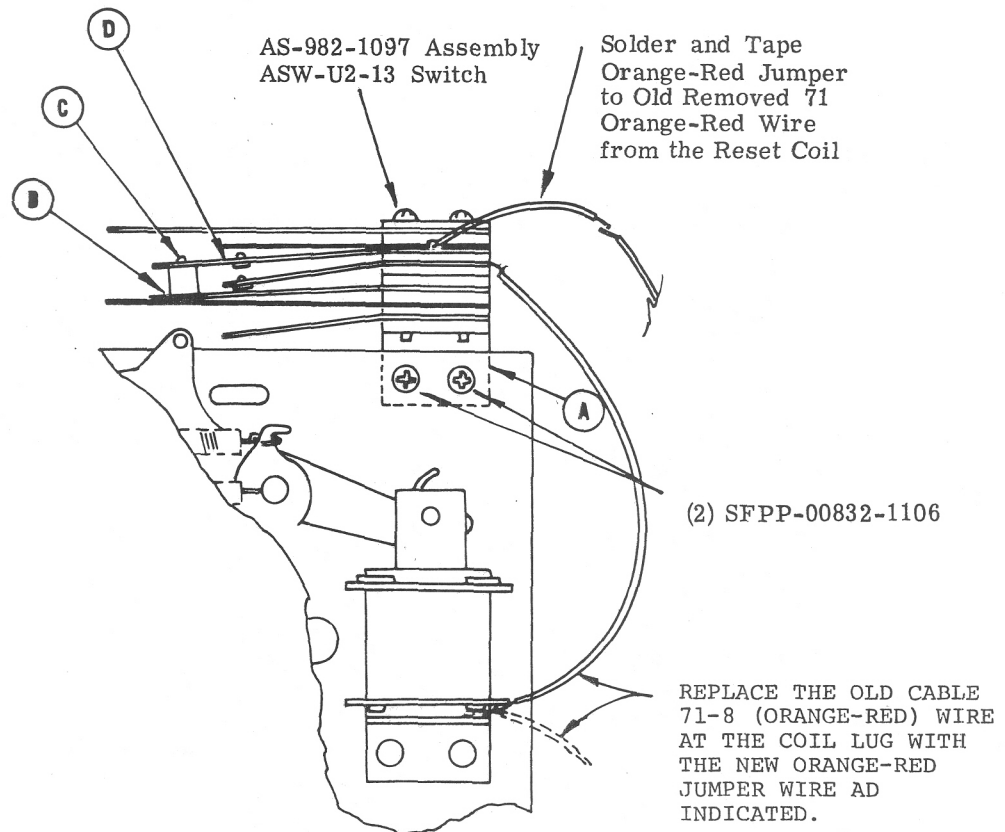

ALWAYS GIVE MODEL AND PART NO. WHEN ORDERING SERVICE PARTS

MYSTIC LINES FEATURE DISC

Switch/Coil	Part No.	Location on Diagram	Wire No.	Wire Color	Function
Mystic Line Step-Up	B-25-9250	G-19	70 58-2	Orange White-Black	Energizes Mystic Line Step-Up Coil
Mystic Line Reset	C-38-1100	B-17	70 85-5	Orange Black-White	Energizes Mystic Line Reset Coil

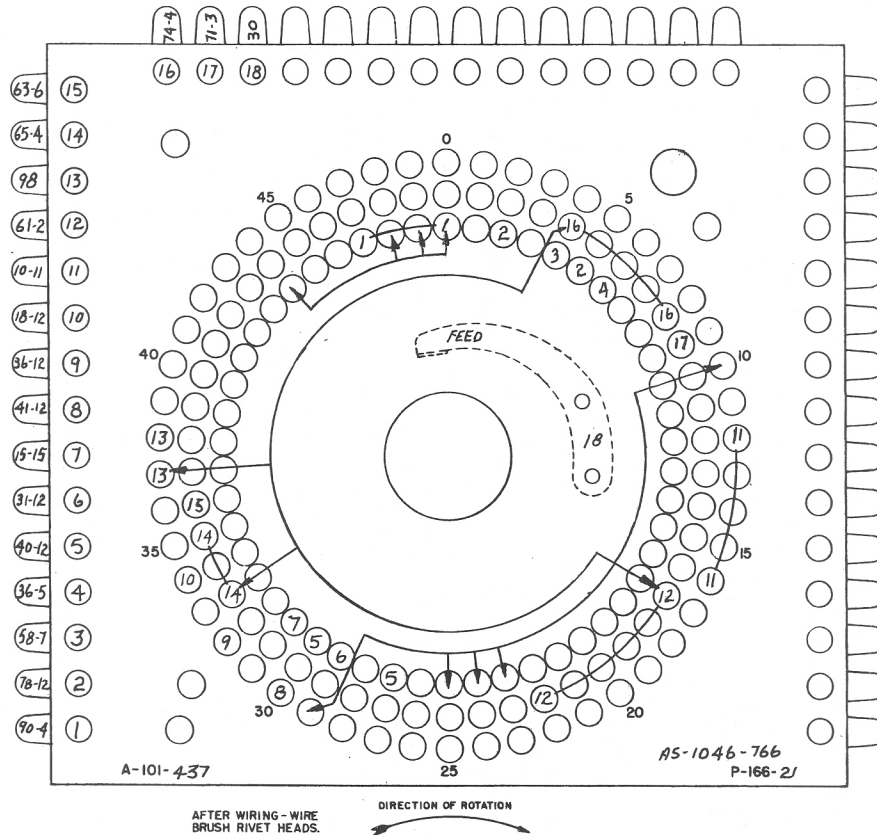

- | | |
|---|--|
| (1) Wiper Fd. for A, B, & C Buttons | (12) Cir. to 16 Pulse Cam Sw. which Step-Up Mystic Lines |
| (2) Feed Cir. to "A" Button | (13) Cir. from Program Disc, "A" Fea. to Reflex Relay #1 |
| (3) Feed Cir. to "B" Button | (14) Cir. from Program Disc, "B" Fea. to Mystic Lines Fea. Disc. |
| (4) Feed Cir. to "C" Button | (15) Cir. from Program Disc, "B" Fea. to Reflex Relay #1 |
| (5) Feed Cir. to "A" Lite | (16) Cir. from Program Disc, "C" Fea. to Mystic Lines Fea. Disc. |
| (6) Feed Cir. to "B" Lite | (17) Cir. from Program Disc, "C" Fea. to Reflex Relay #1 |
| (7) Feed Cir. to "C" Lite | (18) Hot Feed to Disc, 6 Step Unit |
| (8) Feed Cir. to "A" Arrow Lite | |
| (9) Feed Cir. to "B" Arrow Lite | |
| (10) Feed Cir. to "C" Arrow Lite | |
| (11) Feed Cir. to Wiper On Sel. Fea. Disc | |

ALWAYS GIVE MODEL AND PART NO. WHEN ORDERING SERVICE PARTS

SELECTION FEATURE DISC

Switch/Coil	Part No.	Location on Diagram	Wire No.	Wire Color	Function
Selection Fea. Step-Up	B-25-9250	G-22	70 80-7	Orange Black	Energizes feature Step-Up Coil
Selection Fea. Reset	C-38-1100	B-17	70 85-5	Orange Black-White	Energizes Feature Reset Coil

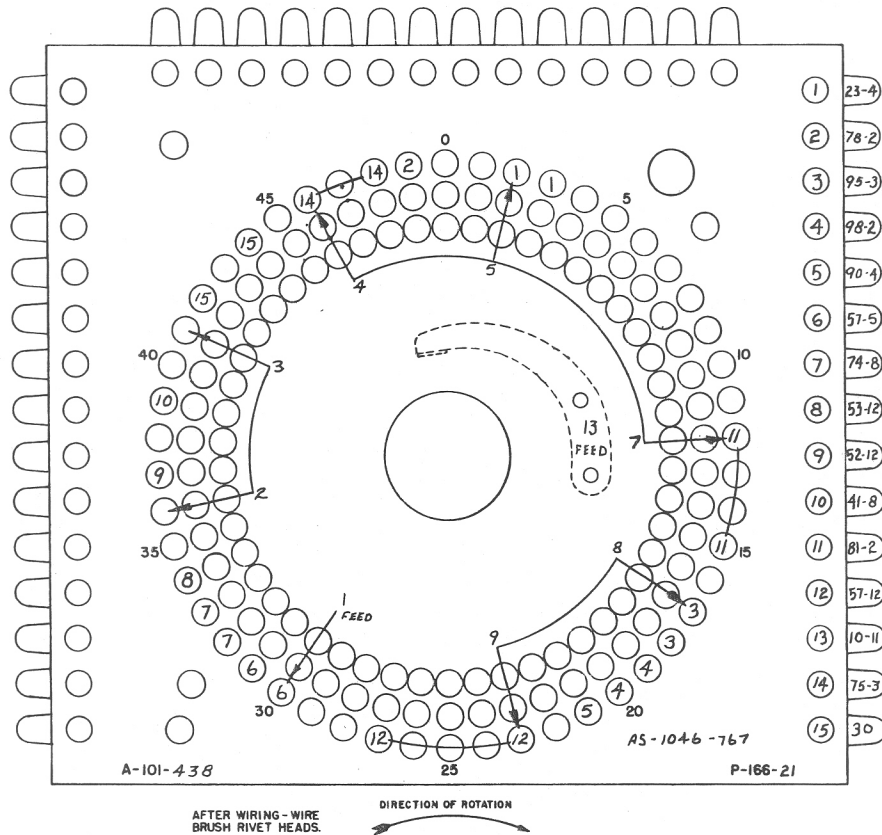

- | | |
|--|--------------------------------------|
| (1) Before 5th Ball Fea. available from Program Disc via Reflex Relay #1 | (8) Circuit to After 5th Lite |
| (2) After 5th Ball Fea. available from Program Disc via Reflex Relay #1 | (9) Cir. to 1st Arrow Lite |
| (3) Before 4th Fea., Cir. Feed to Mystic Lines Fea. Disc. | (10) Cir. to 2nd Arrow Lite |
| (4) Before 5th Fea., Cir. Feed to Mystic Lines Fea. Disc | (11) Cir. to Sel. Fea. Step-Up |
| (5) After 5th Fea., Cir. Feed to Mystic Lines Fea. Disc | (12) Feed Cir. from Search Wiper Cam |
| (6) Circuit to Before 4th Lite | (13) Feed Cir. for Fea. Lites |
| (7) Circuit to Before 5th Lite | (14) Cir. Feed 41 - 8 2nd Arrow Lite |
| | (15) Hot Feed to Disc, 4 Step Unit |

ALWAYS GIVE MODEL AND PART NO. WHEN ORDERING SERVICE PARTS

SCORE UNIT DISCS RED, YEL., GRN. & BLUE

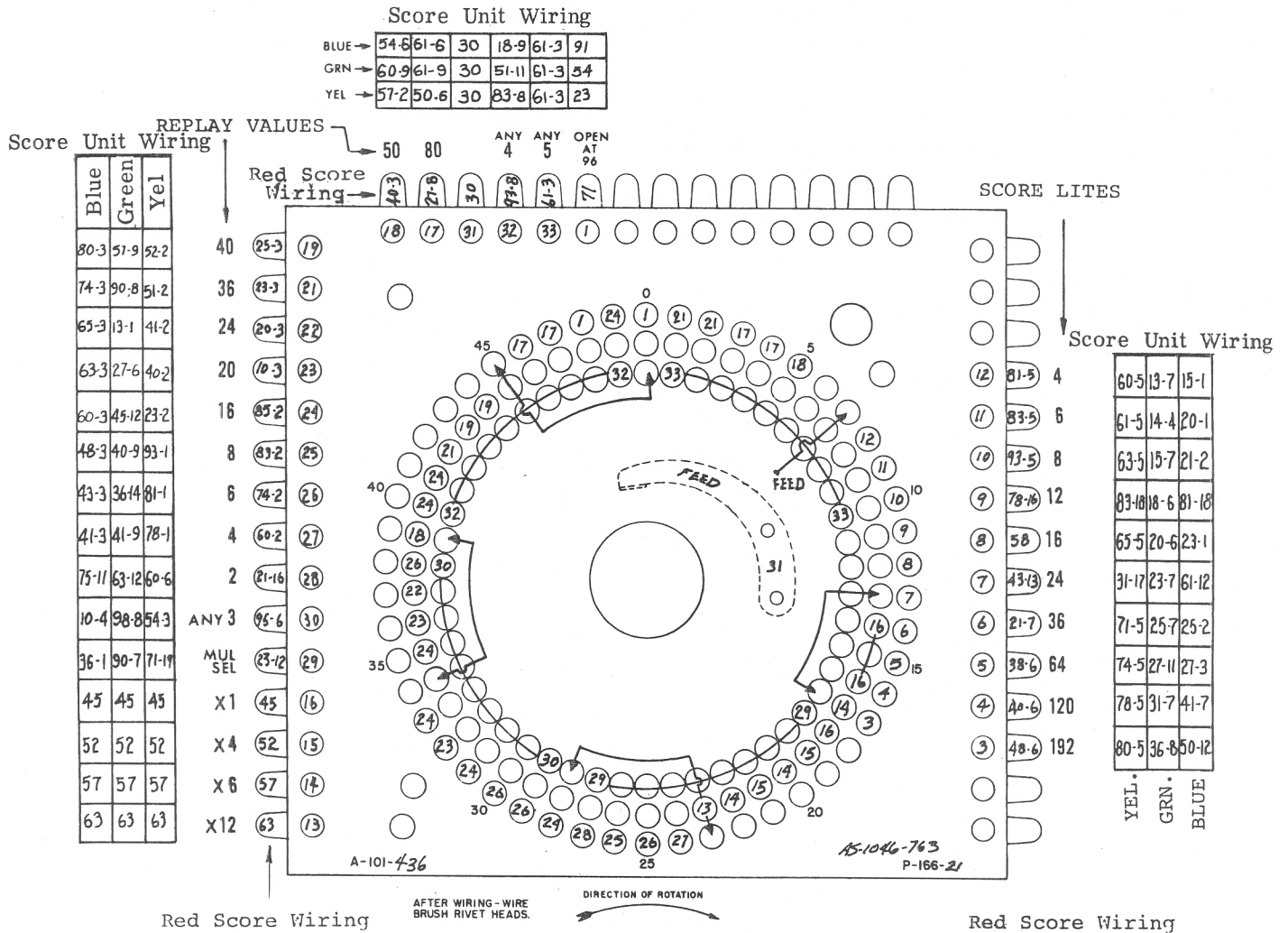

Switch/Coil	Part No.	Location on Diagram	Wire No.	Wire Color	Function
Red Step Up Coil	B-25-925	G-27	70 15-6	Orange Red-White	Energizes Red Score Step-Up Coil
Red Reset Coil	C-28-1100	C-18	70 78-3	Orange Orange-Black	Energizes Red Reset Coil
Open At "O" N. O.	ASW-U2	D-10	14-14 45-8	Red-Green Green-White	Directs Circuit to Shutter Cam #4 Switch
Yellow Step Up Coil	B-25-925	G-27	70 18-2	Orange Red-Black	Energizes Yellow Score Step-Up Coil
Yellow Reset Coil	C-28-1100	G-27	70 78-3	Orange Orange-Black	Energizes Yellow Reset Coil
Green Step Up Coil	B-25-925	G-28	70 20-2	Orange Blue	Energizes Green Step-Up Coil
Green Reset Coil	C-28-1100	C-18	70 78-3	Orange Orange-Black	Energizes Green Reset Coil
Blue Step Up Coil	B-25-925	G-28	70 23-6	Orange Blue-Yellow	Energizes Blue Step Up Coil
Blue Reset Coil	C-28-1100	C-18	70 78-3	Orange Orange-Black	Energizes Blue Reset Coil

ALWAYS GIVE MODEL AND PART NO. WHEN ORDERING SERVICE PARTS

SCRAMBLER DISC

Switch/Coil	Part No.	Location on Diagram	Wire No.	Wire Color	Function
Scrambler	B-25-925	A-18	70	Orange	Energizes Scrambler Step-Up Coil
Step-Up			78-3	Orange-Black	
Scrambler Reset	C-28-1100	A-18	70	Orange	Energizes Scrambler Reset Coil
Reset			31-6	Yellow-Red	

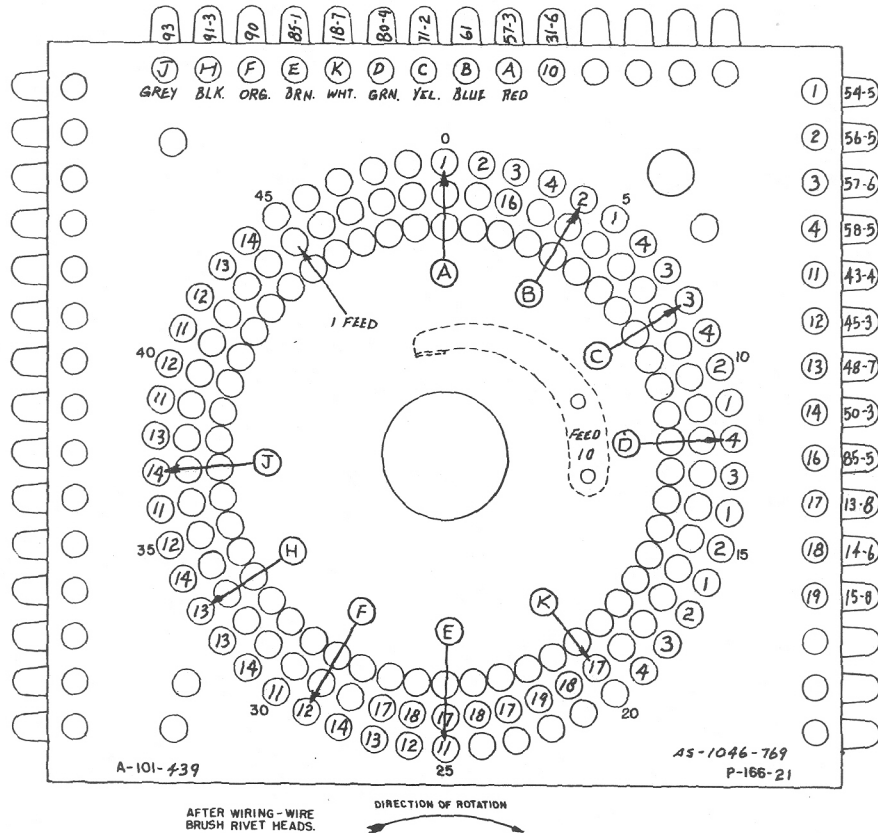

GOLDEN GATE SCRAMBLER DISC

- | | | | |
|------|---|------|--|
| 93 | Double Blue, Wiper Feed from Program Disc to Reflex #2 Re. Switches | 57-3 | Red, Wiper Feed from Program Disc to Red Score Relay, 1st Step |
| 91-3 | Double Green, Wiper Feed from Program Disc to Reflex #2 Re. Switches | 31-6 | Scrambler Reset |
| 90 | Double Yellow, Wiper Feed from Program Disc to Reflex #2 Re. Switches | 54-5 | Circuit to Red Score Relay |
| 85-1 | Double Red, Wiper Feed from Program Disc to Reflex #2 Re. Switches | 56-5 | Circuit to Yellow Score Relay |
| 18-7 | Wiper Feed from before 4th Trip Sw. to Coin Counter Disc | 57-6 | Circuit to Green Score Relay |
| 80-4 | Blue, Wiper Feed from Program Disc to Blue Score Relay, 1st Step | 58-5 | Circuit to Blue Score Relay |
| 71-2 | Green, Wiper Feed from Program Disc to Green Score Relay, 1st Step | 43-4 | Circuit to Double Red Trip Re. |
| 61 | Yellow, Wiper Feed from Program Disc to Yellow Score Relay, 1st Step | 45-3 | Circuit to Double Yellow Trip Re. |
| | | 48-7 | Circuit to Double Green Trip Re. |
| | | 50-3 | Circuit to Double Blue Trip Re. |
| | | 85-5 | Reset Cir., Closed at Top |
| | | 13-8 | Wiper Feeds to Coin Counter Disc |
| | | 14-6 | |
| | | 15-8 | |

ALWAYS GIVE MODEL AND PART NO. WHEN ORDERING SERVICE PARTS

STAR REPLAY COUNTER ADJUSTMENTS

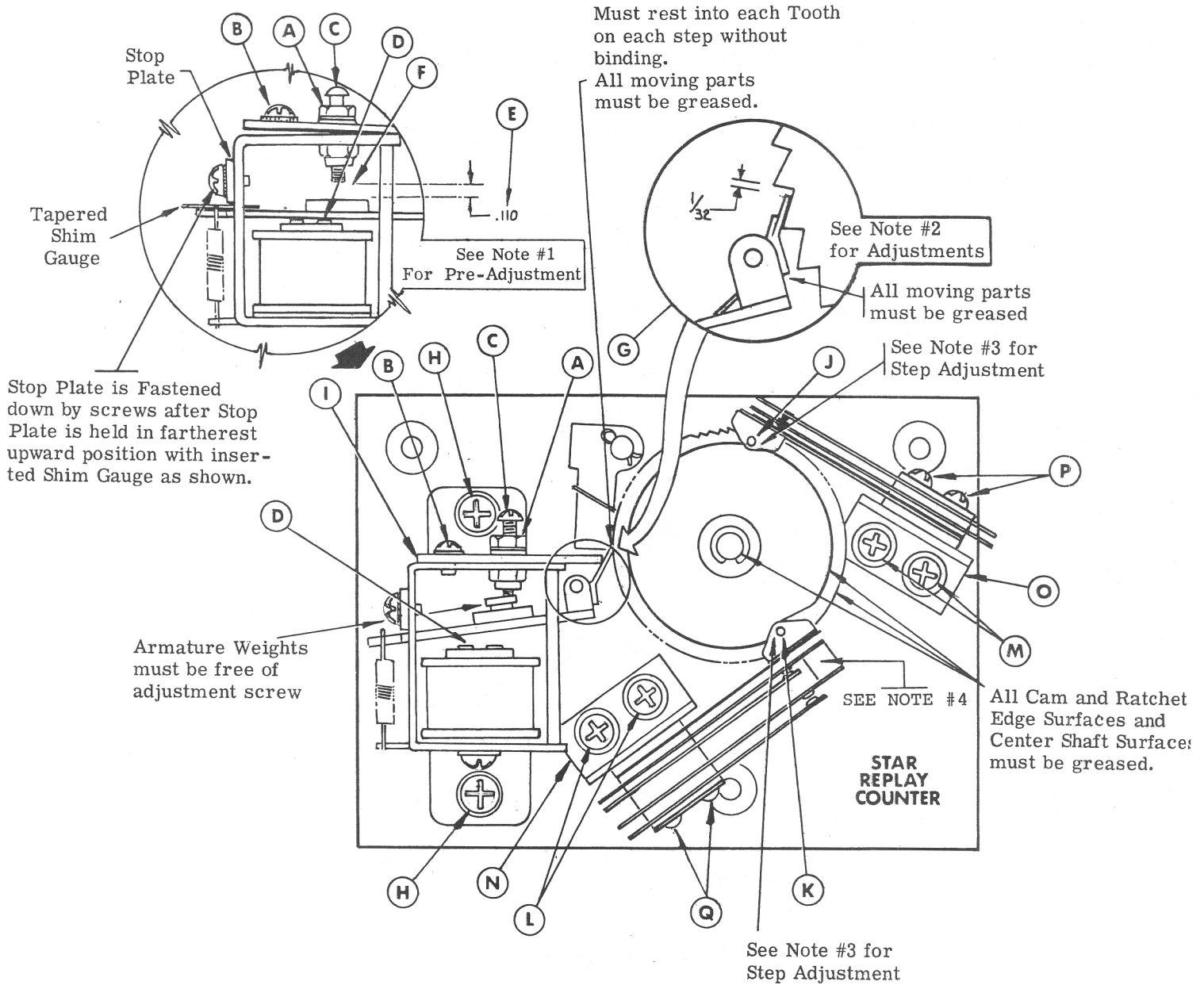

Note #1: Magnet Assembly Pre-Adjustment

- (1) Loosed Lock Nut (A)
 - (2) Loosen Lock Screw (B)
 - (3) Loosen Adjustment Screw (C)
 - (4) While holding the Armature Assy. down to the Coil (D), place the .110 Gauge (E) between the Adjustment Screw (C), and the Armature Assy. as shown at (F) (Screw must clear weights).
 - (5) Tighten down the Screw (C) until the Gauge (E) cannot be removed (do not force).
 - (6) Loosen the Screw (C) slowly until the Gauge (E) may be removed (F) with the feel of rubbing of both the Armature and the Adjustment Screw (C) when removed
 - (7) Tighten Lock Nut (A)
 - (8) Remove the Gauge (E) and recheck the adjustments
- Note: Adjustments may be altered slightly for the Adjustment of the Pawl into the Teeth of the Ratchet (G)

CONTINUED

ALWAYS GIVE MODEL AND PART NO. WHEN ORDERING SERVICE PARTS

STAR REPLAY COUNTER

Note #2: Magnet Assembly Adjustment

- (1) Loosen both Screws (M)
- (2) Loosen Lock Nut (A)
- (3) Adjust the Height of the Magnet Assy. so that upon the Stepping of the Pawl into the Tooth of the ratchet, approximately 1/32 spacing will be visible between the Pawl and the Ratchet Tooth as shown for (G). If done properly, approximately 1/64 free play off the Pawl at rest in the Ratchet Tooth will be visible when the Ratchet is moved by hand.
- (4) Tighten the Screws (H)
- (5) Slide the Stop (I) to rest against the Pawl (do not force). The Pawl should rest against the Stop and Ratchet only.
- (6) Tighten Lock Screw (B)
- (7) Tighten Lock Nut (A)
- (8) Step Up the Magnet Assy. electrically and check to see that the Stepping is all the way into each tooth without missing any steps.
- (9) Recheck all adjustments and re-adjust if necessary. Recheck all adjustments play of the Pawl at rest in the Ratchet Tooth will be visible when the ratchet is moved by Hand.

Note #3: Step Adjustment

- (1) Loosen all the Screws at (L) (Q) (M) and (P).
- (2) Pull back the Switch (J) and Switch Bracket (O) all the way away from the Ratchet Assy., and tighten down the Screws (M).
- (3) While holding the Armature down to the Coil (D), spin the Ratchet so that the Switch Roller (J) will be in the Cam Slot, or near as possible to the Cam Slot.
- (4) Move back the Switch (J) or Switch Bracket (O) toward the Ratchet (if need be) so that the Switch Roller (J) will just barely drop into the Cam Slot (but cleanly), and tighten down the Screws (P).
- (5) Adjust the Switch (J) (See Note #4).
- (6) Step the Ratchet 25 Steps.
- (7) Push the Switch (K) and Switch Bracket (N) all the way toward the Ratchet Assy., and tighten down the Screws (L).
- (8) Move the Switch (K) or Switch Bracket (N) (if need be) so that the Switch Roller (K) will just barely (but cleanly) drop into the Cam Slot, and tighten down the Screws (Q).
- (9) Adjust the Switch (K) (See Note #4).
- (10) Re-check all adjustments.

Note #4: Switch Adjustment

- (1) The lower switch leaf rollers must make at the bottom of the Cam Slot, and on the outer Cam edge without excess bowing of the Switch Leaf, and with the Cam at the Center of the Leaf Rollers.
- (2) The Switch Lifter must ride on the Lower Switch Leaf at all times without excess bowing of the Switch Leaf.
- (3) All All
- (3) All Switches must make on the 3rd or 4th Step from the Starting Point in the Cam Slot.

Switch/Coil	Part No.	Location on Diagram	Wire No.	Wire Color	Function
Star Replay Counter	EA-30-1150	G-90	70 27-17	Orange Blue-Orange	Energizes Star Replay Coil Counter
Homing Cam Sw. N. O.	ASW-C1-6	G-9	27-17 80-16	Blue-Orange Black	Completes Circuit to Star Replay Coil to Reset Cam
A. N. C.	ASW-C1-6	K-9	57-1 85-10	White-Orange Black-White	Opens at 25 Star Replay Counter Opening Circuit to Search Disc
B. N. C.	ASW-C1-8	J-9	58-3 23-14	White - Black Blue-Yellow	Opens Circuit to Search Disc

ALWAYS GIVE MODEL AND PART NO. WHEN ORDERING SERVICE PARTS

ALTERNATOR UNIT

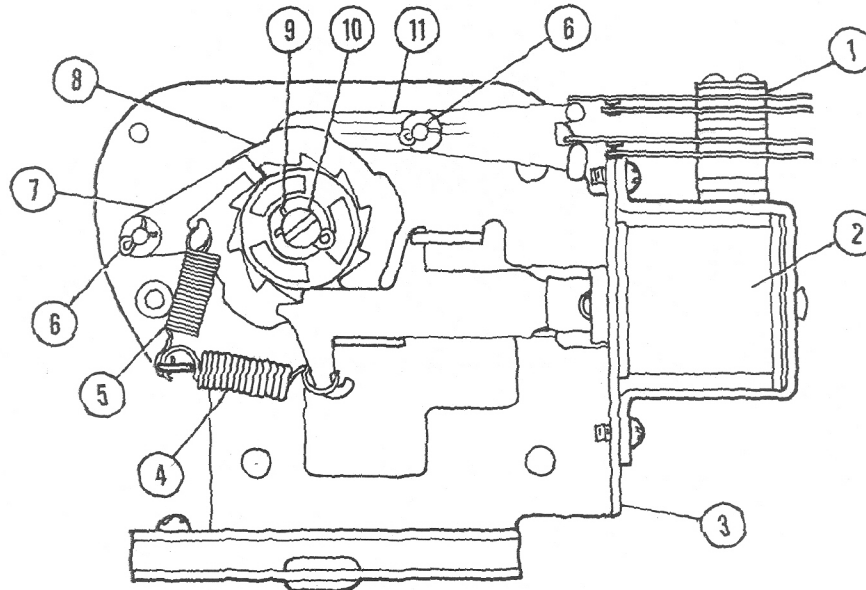

ALTERNATOR PARTS LIST

Description	Part No.
1 Switch	ASW-M200-3
2 Coil	CT-28-1100
3 Base Plate	A-2214-30
4 Extension Spring	SP-100-80
5 Extension Spring	SP-100-276
6 Hair Pin	M-254
7 Holding Pawl	C-708
8 Ratchet - 10 Tooth - 5 Lobes	C-704-2
9 Hair Pin	M-254
10 Pin	S-2028
11 Rocker Arm	C-703-1

Switch/Coil	Part No.	Location on Wire Diagram	Wire No.	Wire Color	Function
Alternator Unit	C-28-1100	G-11	70 75-6	Orange Orange-White	Energizes Alternator Coil
Homing Sw. N. O.	ASW-M200-3	G-11	43-15 75-6	Green-Yellow Orange-White	Completes Circuit to Alternator Coil
Segments Sw.	ASW-M200-3	G-11	90-1 70	Grey Orange	Multiplier Sw. Cir. Fed from Replay Cam X2 C. U.

ALWAYS GIVE MODEL AND PART NO. WHEN ORDERING SERVICE PARTS

PANEL SHUTTER MOTOR UNIT PANEL LIFTER START RELAY

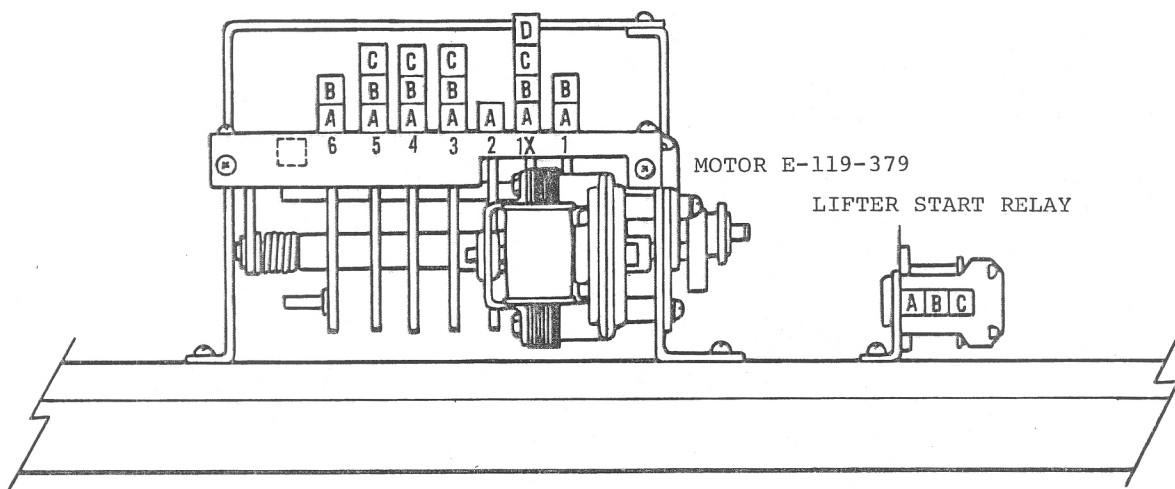

Switch/Coil	Part No.	Location on Diagram	Wire No.	Wire Color	Function
Motor	E-119-379	A-9	70 53-5	Orange White-Yellow	Energizes Shutter Motor
#1 Cam	ASW-C1-27	E-9	53-5 30	White-Yellow Yellow	Completes Circuit to Shutter Motor
A. N.O.					
B. N.C.	ASW-C2-15	A-9	45-18 61-7	Green-White Brown-Red	Opens Circuit to Timer Cams Index Coil
#1X Cam	ASW-C1-27	B-16	65-6 52-6	Brown-White White-Blue	Completes Circuit to Gate Lift Motor via Timer Disc
A. N.O.					
B. N.O.	ASW-C1-8	F-14	80-10 13-11	Black Red-Yellow	Completes Pulsing Circuit to 40 Coin Limit Lite
C. N.C.	ASW-C2-15	D-13	50 21-3	White Blue-Red	Open when Shutter Open Sw. directs Circuit to B-5 Trip Sw. (Timer Step-Up, Reset Circuit)
D. N.C.	ASW-C2-2	L-15	15-5	Red-White	Opens Circuit to Search Relays
#2 Cam	ASW-C1-27	D-15	31-3 36-3	Yellow-Red Yellow-Brown	Closed when Shutter Open completes Circuit to Manual Button Sw. & Ball Lift Relay Sw.
A. N.O.					
B. N.O.	ASW-C1-28	C-4	90-10 30	Grey Yellow	O. W. O. SW. Directs Circuit to Trip Bank Reset Motor
C. N.O.	ASW-C1-28	D-16	65-6 30	Brown-White Yellow	O. W. O. Sw. completes Circuit to Golden Gate Lift Motor
#4 Cam	ASW-C1-27	L-4	21-3 10-13	Blue-Red Red	O. W. O. Sw. directs Circuit to Lifter Start Relay Sw. , B-4 Trip Sw. & Search Wiper Cam Sw.
A. N.C.					
B. N.O.	ASW-C2-15	C-10	53-5 18-3	White-Yellow Red-Black	C. W. O. Sw. directs Circuit to Shutter Motor
C. N.O.	ASW-C2-2	D-10	45-8 18-3	Green-White Red-Black	C. W. O. Sw. directs Circuit to "B" Sw. # Cam, Shutter

ALWAYS GIVE MODEL AND PART NO. WHEN ORDERING SERVICE PARTS

PLAYFIELD PANEL UNITS

Switch/Coil	Part No.	Location on Diagram	Wire No.	Wire Color	Function
#5 Cam A. T.	ASW-C3-8	A-9	53-5 10-10 45-18	White-Yellow Red Green-White	53-5 Circuit to Shutter Motor. , 45-18 directs Cir. to Timer Cams Index Coil
B. N. O.	ASW-C2-3	D-14	31-4 90-9	Yellow-Red Grey	Directs Circuit to Ball Gate Sw. (Lifter Start Relay Circuit)
C. N. O.	ASW-C2-2	G-10	38-9 80-16	Yellow-Black Black	C. W. O. Circuit to Multiple #1 Relay Sw.
#6 Cam A. N. O.	ASW-C10-5	E-14	71-8 30	Orange-Red Orange	Completes Circuit to Timer Reset Coil
B. N. O.	ASW-C10-1	C-17	78-3 30	Orange-Black Orange	Circuit to Score Reset Coils & Scrambler Step-Up Unit
C. N. O.	ASW-C10-1	C-4	90-10 30	Grey Yellow	Completes Circuit to Trip Bank Reset Motor
Shutter Sws. A. N. C.	ASW-C1-29	C-8	98-6 91-11	Grey-Black Grey-Red	O. W. O. Sw. directs Circuit to Coin Lockout Coil
B. N. C.	ASW-C1-29	C-8	61-8 51-8	Brown-Red White-Red	O. W. O. Sw. directs Circuit to Search Index Sw. (Start Relay Coil Circuit)
C. C. W. O. C. W. O.	ASW-C111-1	K-6	21-3 27-15 83-11 57-14	Blue-Red Blue-Orange Black-Yellow White-Orange	Closed when open Sws. Reset the Mystic Lines into their Home Positions via Mystic Line Discs.
Lifter Start Relay	G-32-2500	A-14	70 38-8	Orange Yellow-Black	Energizes Lifter Start Relay Coil
A. N. O.	ASW-R1-8	D-14	36 38-8	Yellow-Brown Yellow-Black	Completes Circuit to Lifter Start Relay Coil
B. N. C.	ASW-R2-5	J-3	10-13 65-13	Red Brown-White	Opens Circuit to Ball Lifter Cam #1 Sw.
C. N. C.	ASW-R2-5	E-15	21-3 31-3	Blue-Red Yellow-Red	Opens Circuit to Shutter Cam #2
Ball Gate Sw. N. C.	ASW-A2-5	C-14	31-4 36	Yellow-Red Yellow-Brown	Opens Circuit to Lifter Start Relay Sw.
Runway Ball Sw. N. O.	ASW-A1-30	D-15	38-8 30	Yellow-Black Yellow	Completes Circuit to Lifter Start Relay Coil
Ball Lifter Motor	E-119-338	A-15	70 38-3	Orange Yellow-Black	Energizes Ball Lift Motor
#1 Cam A. N. O.	ASW-C2-15	C-15	91-1 30	Grey-Red Yellow	Completes Circuit to, Timer Open at "O" Sw.
B. N. C.	ASW-C1X	J-3	65-13 85-6	Brown-White Black-White	Opens Circuit to Timer Disc
#2 Cam N. O.	ASW-C1X	C-12	43-2 27-2	Green-Yellow Blue-Orange	Directs Circuit to Replay Cam Index Sw.

ALWAYS GIVE MODEL AND PART NO. WHEN ORDERING SERVICE PARTS

STEPPING UNITS SW. & COIL CHART

Switch/Coil	Part No.	Location on Diagram	Wire No.	Wire Color	Function
Trough Sws. #1 Sw. N.O.	ASW-A2-62	H-3	75-16 83-6	Orange-White Black-Yellow	Trough Sw. closed when 4th Ball Up Circuit to Before 4th Trip Sw.
#5 Sw. N.O.	ASW-A1-20	B-15	91-1 38-3	Grey-Red Yellow-Black	Opens Circuit to Ball Lift Motor
Ball Lifter Sw. N.O.	ASW-A1-7	D-11	21-3 81-3	Blue-Red Black-Red	Completes Circuit to Ball Lifter Relay
"A" Button Sw. N.O.	ASW-A1-24	H-4	45-5 78-12	Green-White Orange-Black	Directs Circuit to "B" Cam Relay
"B" Button Sw. N.O.	ASW-A1-24	H-4	48-5 58-7	Green-Black White-Black	Directs Circuit to "C" Cam Relay
"C" Button Sw. N.O.	ASW-A1-24	H-5	25-6 36-5	Blue-White Yellow-Brown	Directs Circuit to "B" Cam Relay
"Gate" Sw. N.O.	ASW-A1-24	D-16	21-3 63-7	Blue-Red Brown-Yellow	Directs Circuit to Golden Gate Trip Relay
"R" Button Sw. A. N.O.	ASW-A11-4	J-3	53-18 52-9	White-Yellow White-Blue	Directs Circuit to Search Wiper Cam Sw.
B. N.O.	ASW-A11-4	C-13	85-8 71-8	Black-White Orange-Red	Completes Circuit to Timer Reset Coil
Coin Lock Out Mag.	M-37-2700	A-8	70 91-13	Grey-Red	Energizes Coin Lock out Mag.
Manual Lift Button N.O.	ASW-A2-9	D-15	91-1 36-3	Grey-Red Yellow-Brown	Directs Circuit to Timer Open at "O" Sw.
B. N.C.	ASW-A1-26	D-15	31-4 30	Yellow-Red Yellow	Opens Circuit to Ball Gate Sw.
Coin Sw. N.O.	AS-277-105	D-7	13-9 27-9	Red-Yellow Blue-Orange	Directs Circuit to Control Unit Cam #3
Meter Lite	#55 Bulb	F-21	81-4 93-6	Black-Red Grey-Yellow	Energizes Meter Lite via Door Sw.
Frt. Door Lite Sw. N.O.	ASW-M2-6	F-21	93-6 30	Grey-Yellow Yellow	Closes when Door Opens energizing Lite
Cabinet Toggle Sw. N.O.	E-108-57	D-1	90 P 70 P	Grey Orange	Completes Circuit to Fuses & Transformer
Door Tilt Sw. N.O.	ASW-A1-25	B-11	14-5 21-3	Red-Green Blue-Red	Completes Circuit to Tilt Trip Coil
Frt. Door Sw.	ASW-A1-15	G-8	40-7 70	Green Orange	Normally Closed Completes Circuit to Replay Meter
Back Door Sw.	ASW-A1-16	G-8	98-4 40-7	Grey-Black Green	Located next to Top Lock, Normally Closed complete cir. to Replay Meter
Play Button Sw. N.O.	ASW-A1-37	D-7	50-2 63-2	White Brown-Yellow	Directs Circuit to Replay Reg. Open at "O" Sw.
Total Replay Meter	E-130-10	H-8	93-7 41-4	Grey-Yellow Green-Red	Energized via Control Unit Cam #13 1X
Total Play Meter	E-130-10	H-8	80-9 91-7	Black Grey-Red	Energized via Control Unit Cam #7
Single Coin Meter	E-130-10	A-9	70 80-2	Orange Black	Energizes Coin Meter via Control Unit Cam #4
Key Meter	E-130-10	G-8	70 63-10	Orange Brown-Yellow	Energizes Key Meter via Key Sw.
Key Sw. A. N.C.	ASW-B0-4	A-7	98-10 13-16	Grey-Black Red-Yellow	Opens Circuit to Start Relay Coil
Key Sw. B. N.O.	ASW-B-1	G-8	63-10 80-19	Brown-Yellow Black	Completes Circuit to Key Meter
Key Sw. C. N.O.	ASW-B-2	E-3	78-4 30	Orange-Black Yellow	Completes Circuit to Anti-Cheat Relay Coil
Key Sw. D. N.O.	ASW-B-2	B-11	14-5 21-3	Red-Green Blue-Red	Tilt Trip Sw. completes Circuit to Tilt Trip Coil
Key Sw. E. N.O.	ASW-B0-7	H-7	50-11 93-3	White Grey-Yellow	Completes Circuit to Replay Register Step-Up

ALWAYS GIVE MODEL AND PART NO. WHEN ORDERING SERVICE PARTS

STEPPING UNITS SW. & COIL CHART

Switch/Coil	Part No.	Location on Diagram	Wire No.	Wire Color	Function
Key Sw. T.	ASW-C3-6	H-7	75-9 80-19 93-3	Orange-White Black Grey-Yellow	75-9 Replay Cir. via Multplay Relay 93-3 Replay Cir. via Key Sw.
Mystic Gate Motor	E-119-353	A-16	70 65-6	Orange Brown-White	Energizes Mystic Gate via Mystic Gate Trip Relay
Carryover Sw. N. O.	ASW-C1-23	D-16	30 65-6	Yellow Brown-White	Carryover Energizes Lift Motor
Rebound Sw. N. O.	ASW-C1-8	F-14	13-11 51-12	Red-Yellow White-Red	Completes Circuit to Mystic Gate Insert & Panel Lite
Rebound - Up Sw. N. O.	ASW-A1-43	C-16	74-7 65-6	Orange-Green Brown-White	Completes Circuit to Lift Motor
Reflex Play-Mag	EA-32-1550	B-6	70 80-9	Orange Black	Energizes Reflex play Magnet
Reflex Replay-Mag.	EA-30-1150	G-8	70 41-4	Orange Green-Red	Energizes Reflex Replay Magnet

ALWAYS GIVE MODEL AND PART NO. WHEN ORDERING SERVICE PARTS

MOTOR PARTS GUIDE

CONTROL UNIT MOTOR E-119-462

Index No.	Part No.	Description	No. Req.
1	GC3-4023-1	Transmission Unit	1
2	ASS-4023-1	Stator Unit	1
3	ABB-1010-00	Bearing & Brkt. Assy.	1
4	S-1011-01	Fan	1
Note: Order Index No.'s 5 - 7 as a unit			
5	AR3-4023-1	Rotor & Shaft Unit	1
6	W-1014-03	Rotor Shaft Washer	1
7	W-1017-25	Rotor Shaft Washer	1
	W-1016-03	Rotor Shaft Washer	1
	W-1016-12	Rotor Shaft Washer	3

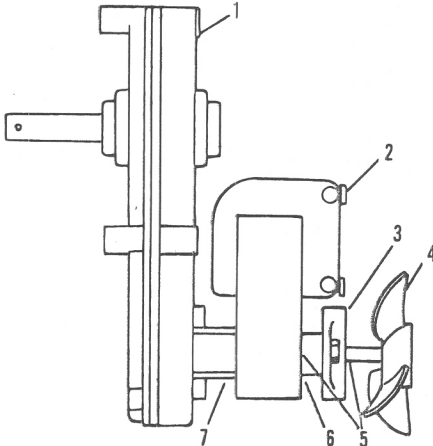

TRIP BANK RELAY MOTOR E-119-464

Index No.	Part No.	Description	No. Req.
1	GC2-2543-1	Transmission Unit	1
2	AS2-2543-1	Stator Unit	1
3	ABB-1010-01	Bearing & Brkt. Assy.	1
Note: Order Index No.'s 4 - 6 as a unit			
4	AR2-2543-1	Rotor & Shaft Unit	1
5	W-1015-03	Rotor Shaft Washer	1
6	W-1014-03	Rotor Shaft Washer	1
	W-1014-09	Rotor Shaft Washer	3

PANEL SHUTTER MOTOR E-119-379

Index No.	Part No.	Description	No. Req.
1	GC2-1725-1	Transmission Unit	1
2	AS2-1725-1	Stator Unit	1
3	ABB-2010-01	Bearing & Brkt. Assy.	1
Note: Order Index No.'s 4 - 6 as a unit			
4	AR2-1725-1	Rotor & Shaft Unit	1
5	W-1015-03	Rotor Shaft Washer	1
6	J-1011-60	Shaft Shim Spring	1

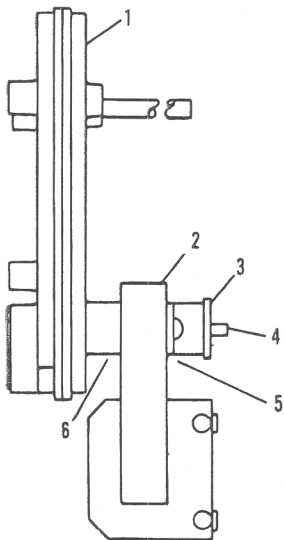

BALL LIFTER MOTOR E-119-339

Index No.	Part No.	Description	No. Req.
1	GC2-1743-1	Transmission Unit	1
2	AS2-1743-1	Stator Unit	1
3	ABB-1010-1	Bearing & Brkt. Assy.	1
Note: Order Index No.'s 4 - 6 as a unit			
4	AR2-1743-1	Rotor & Shaft Unit	1
5	W-1015-03	Rotor Shaft Washer	1
6	J-1011-60	Shaft Shim Spring	1

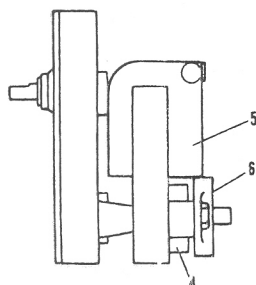
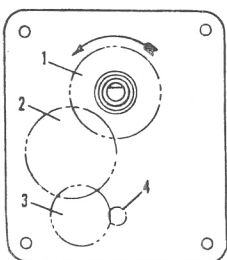

Mystic Line 'A' Motor E-119-457

Index No.	Part No.	Description
1	VSI-1725-2	Gear & Shaft Assem.
2	V-5818-10	Intermediate Gear
3	V-4209-10	Intermediate Gear
4	ARI-1725-2	Rotor & Shaft Assem.
5	ASI-1725-2	Stator & Coil Assem.
6	ABB-1010-01	Frnt. Rotor Bearing & Brkt. Assem.

Mystic Line 'B & C' Motors E-119-353

Index No.	Part No.	Description
1	VSI-1745-1	Gear & Shaft Assem.
2	V-5818-11	Intermediate Gear
3	V-4216-10	Intermediate Gear
4	ARI-1745-1	Rotor & Shaft Assem.
5	ASI-1745-1	Stator & Coil Assem.
6	ABB-1010-01	Frnt. Rotor Bearing & Brkt. Assem.

MYSTIC GATE PARTS GUIDE

FRONT CABINET ASSEMBLY

Part No.	Description
CA-1119-45	Front Cabinet
M-281-58	Lock (Replay Switch)
AS-982-1030	Top Replay Switch
AS-982-671	Bottom Replay Sw.
A-1533	Coin Slide Assy.
AS-186-11	Ball Lifter Assy.
AS-187-17	Ball Shooter Assy.
A-100-7	Knob & Shooter Rod
SP-243	Compression Spring 1"
SP-200-24	Compression Spring 6"
R-108-3	Shooter Tip
P-2891-8	Retaining Ring
E-108-57	Game On-Off Sw.
A-2618	Legs
M-106-1	Leg Bolt (8)
M-163-4	Leg Adjuster
N3-816-1110	Leg Adj. Nut
A-2790-59	Cash Box
P-3089-55	Cash Box Cover
P-921-39	Chrome Glass Molding - LF
P-921-40	Chrome Glass Molding RT
G-213	Top Glass
CA-439-28	Ball Return Panel

FRONT MOLDING ASSEMBLY

Part No.	Description
AS-1305-60	Front Molding Assy. (complete)
P-2210-8	Coin Drop Plate (5¢ - No Numerical)
P-2210-9	Coin Drop Plate (10¢ - No Numerical)
P-2210-12	Blank Plate (no hole)
P-2210-150	Coin Drop Plate (5¢)
P-2210-151	Coin Drop Plate (10¢)
P-2210-152	Coin Drop Plate (25¢)
P-2210-188	Coin Drop Plate (1 Kr.)
P-2210-187	Coin Drop Plate (1 Fr.)
A-1272-17	"A" Button & Pin Assy.
A-1272-18	"B" Button & Pin Assy.
A-1272-19	"C" Button & Pin Assy.
A-1272-29	"R" Button & Pin Assy.
A-1272-63	"Gate" Button & Pin Assy.
SP-200-111	Button Compression Spring
P-801-214	Washer (Buttons)
P-448-6	Snap Washers (Buttons)

FRONT DOOR ASSEMBLY

Part No.	Description
AS-2041-82	Front Door Assembly (complete)
M-281-54	Lock
A-254-117	Hinge Assembly
M-1400-Series	Slug Rejector (specify Coin Denomination)
AS-2517-14	Coin Lockout Assembly
AS-2744	Coin Sw. & Wire Assy.
P-6431-Series	Coin Guide Spacer (Specify Coin Denomination)
P-6694-Series	Coin Guide (Specify Coin Denomination)
A-1729-16	Push Button Assy. (Replay)
P-800-2	Washer
P-2891-7	Retaining Ring
ASW-A1-15	Replay Switch
ASW-A1-27	Tilt Switch

PLAYFIELD PANEL

Part No.	Description
AS-2042-157	Panel Assembly (Complete w/all Units Installed)
CA-638-93	Panel
CA-1100-8	Arch Bottom
CA-1103	Arch Guide Strip
CA-1104-2	Arch Top
CA-529-17	Shutter
C-326-9	Light Shield Post (white)
E-125-2	Light Bulb #47 (8 req'd)
M-170	Rebound Spring Unit (8 req'd)
SP-112-1	Short Panel Spring (2 req'd)
M-170	Playfield Pin Springs (8 req'd)
S-1071-84	Panel Pins (43 req'd)
C-119-21	Red Bumper Post (2)
R-243-2	Red Bumper Rubber (2)
C-119-23	Yellow Bumper Post (26)
R-243	Yellow Bumper Rubber (22)
R-135	Double Bumper Rubber (2)
R-115-30	Rebound Rubber - Top
AS-1315	Ball Gate & Sw. Assy.
C-153	Red Plastic Ball Lift Cover
SP-112	Yellow Bumper Post (26) Long Panel Spring (7 Req'd)

ALWAYS GIVE MODEL AND PART NO. WHEN ORDERING SERVICE PARTS

MYSTIC GATE PARTS GUIDE

BACK CABINET

Part No.	Description
G-292-38	Back Glass
CA-1120-46	Back Cabinet (painted)
M-475-1	Nut (2 req'd) glass molding retainer
CA-1173	Wood Side Molding - RT.
CA-1173-1	Wood Side Molding - LF
P-2830	Lock Bracket (2)
M-281-31	2 Lock Set
P-2831	Lock Retainer (2)
E-126	Cord Set
A-1511-34	Back Door Hinge - Top
A-1511-33	Back Door Hinge - Bottom
A-1450-3	Insert Hinge & Stud Unit (2)
A-3400-187	Wood Insert & Light Socket Assy.
E-125-5	Light Bulb No. 55 (90)
E-125-2	Light Bulb No. 47 (6)

BACK DOOR ASSEMBLY

Part No.	Description
CA-1120-47	Back Door (Painted)
P-2335-48	Hinge (2)
M-281-24	2 Lock Set
P-758-31	Lock Cam (2)
R-206-1	Rubber Bumper (2) (Outside Door)

MOLEX HT 2038 EXTRACTOR & PIN

NOTE: The Molex Pin Extractor Tool enables easy service of the Molex Plug, Pins both male and female are removable. Holding Extractor Tool as shown in Illustration, placing Forefinger over shaft as to hold it from turning (as shown), push Shaft over Pin giving Tool a slight twist allowing the Pin Fins to compress easily, thus enabling the Pin to be pushed through Nylon Housing.

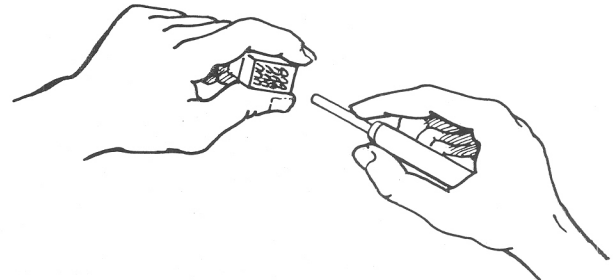

Female BALLY NO.	MOLEX NO.	TYPE
FEMALE E-663-2	02-09-1104	1190
FEMALE E-663-4	02-09-1119	1381
MALE E-661-2	02-09-2103	1189
MALE E-661-4	02-09-2118	1380

TYPE 1189-90 LONG EAR
 TYPE 1380-81 SHORT EAR
 HAND CRIMPING TOOL HT-1031

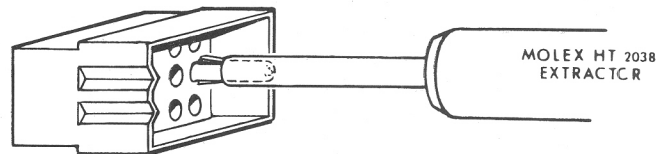

NOTE: REPLACEMENT ITEMS CAN BE ORDERED THRU BALLY DIST. OR NEAREST MOLEX REP. IN COUNTRY OF USE.

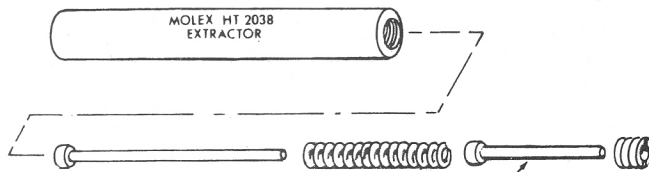
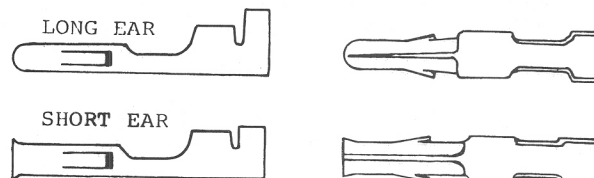

REPLACEMENT PART HT 1010-232

ALWAYS GIVE MODEL AND PART NO. WHEN ORDERING SERVICE PARTS

For Amusement Only

No Prizes or Gambling Permitted

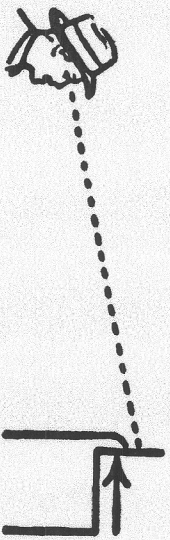

TACK SIGN TO BACK OF
TOP-MOULDING OF BACK-BOX